

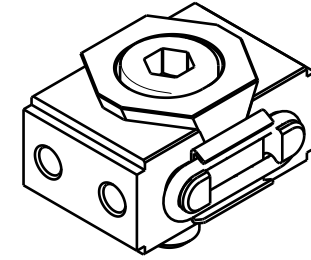

FILE NAME:

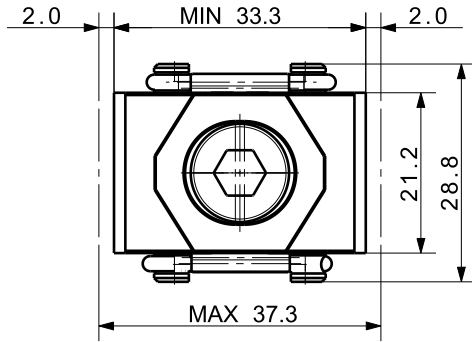

Isometric view (1:2)

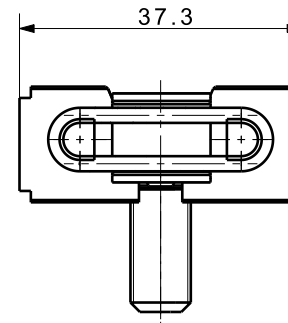
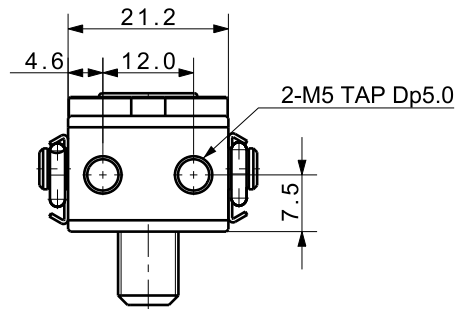
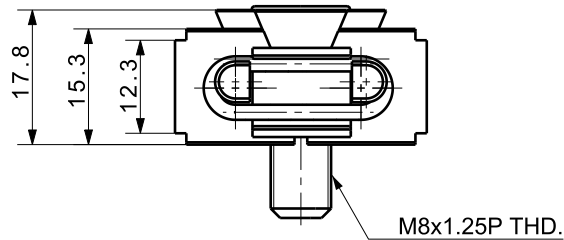

Clamping State

UNLESS OTHERWISE SPECIFIED DIMENSIONS ARE IN MM ALL SURFACES TOLERANCES ANGLE ± X ± .X ± .XX ±	SIGNATURES	MO-DA-YR	 (주)케이제이에프 TOTAL CLAMPING SYSTEMS	
	DRAWN			
	FINISH	WORK ORDER NO	REF DWG NO.	DWG NO.
HEAT TREAT		---	STC-0812F_-	
			SCALE	TOOL <input type="checkbox"/> PART <input type="checkbox"/> SHEET OF

SIDE TAPER CLAMP

