

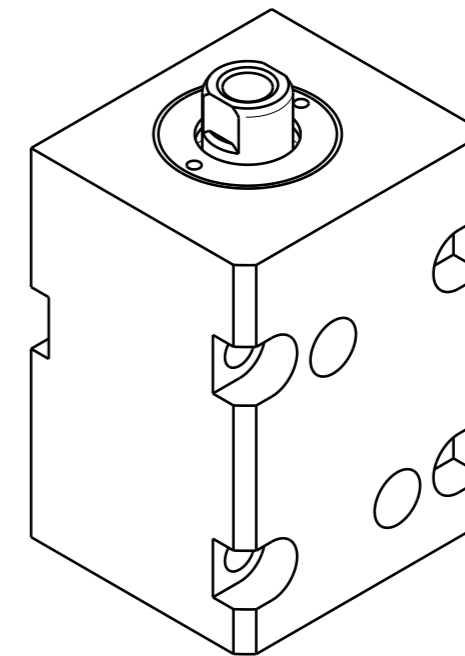

FILE NAME:

REVISIONS				
ZONE	LTR	DESCRIPTION	DATE	APPROVED

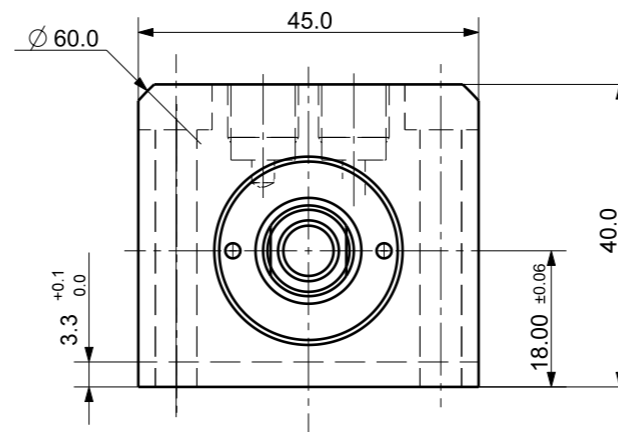
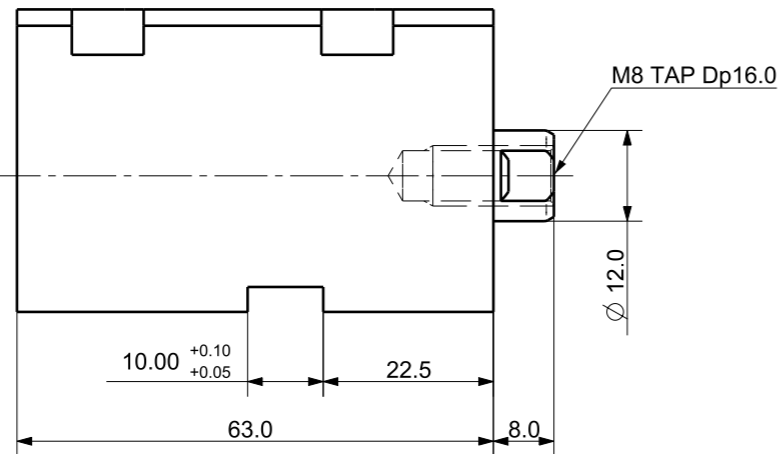
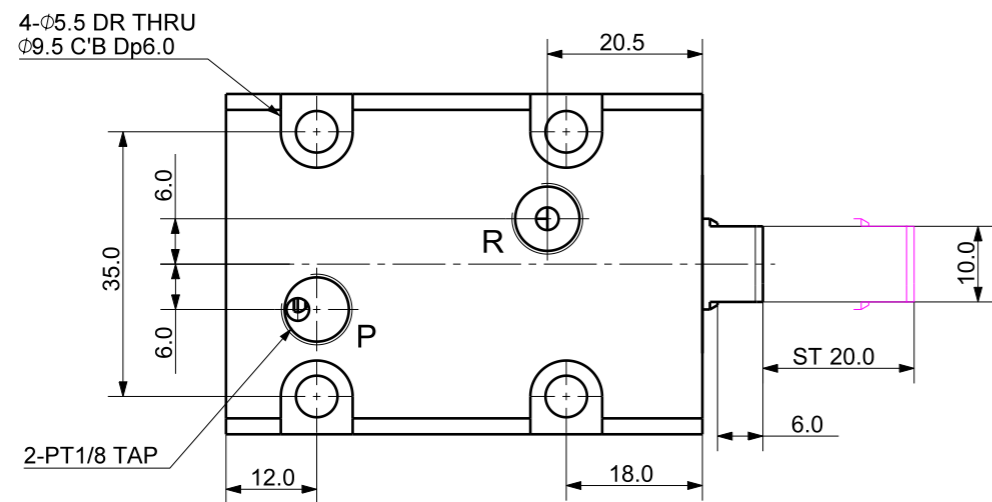

Isometric view (1:1)

DET. NO	NAME	QTY	MAT'L	FINAL SIZES & PART No	REMARK

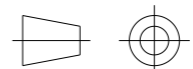
UNLESS OTHERWISE SPECIFIED	SIGNATURES	MO-DA-YR	 케이제이에프(주) TOTAL CLAMPING SYSTEMS BLOCK CLAMP		
DIMENSIONS ARE IN MM	DRAWN				
ALL SURFACES 6.3S	CHECKED				
TOLERANCES	APPROVED				
ANGLE					
X. \pm					
.X \pm 0.15					
.XX \pm					
FINISH	WORK ORDER NO	REF DWG NO.	DWG NO		
		---	BDH-2020_B	A3	
HEAT TREAT		SCALE	TOOL <input type="checkbox"/> PART <input type="checkbox"/> SHEET	OF	