

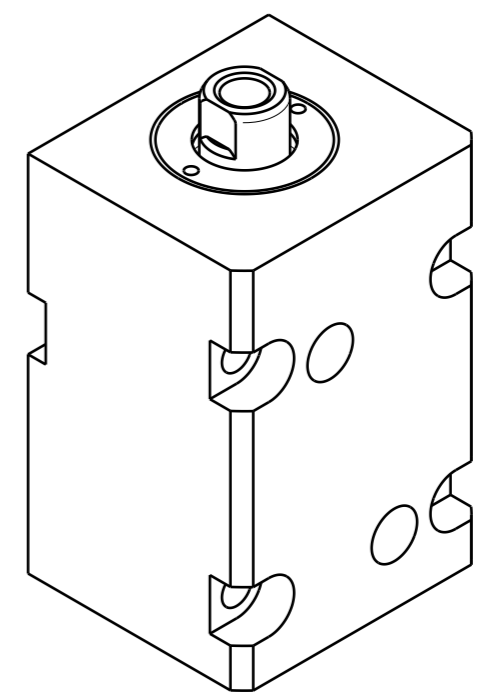

FILE NAME:

| REVISIONS | | | | |
|-----------|-----|-------------|------|----------|
| ZONE | LTR | DESCRIPTION | DATE | APPROVED |
| | | | | |

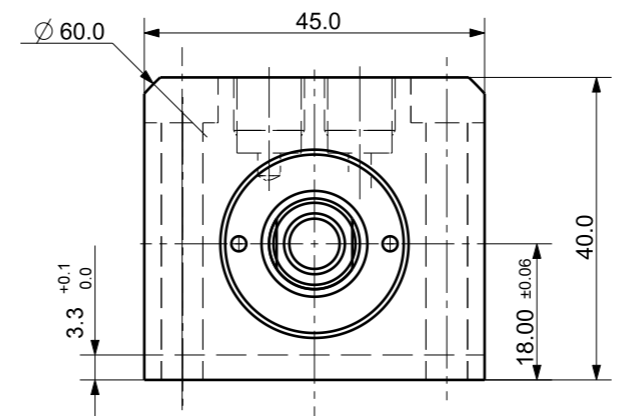
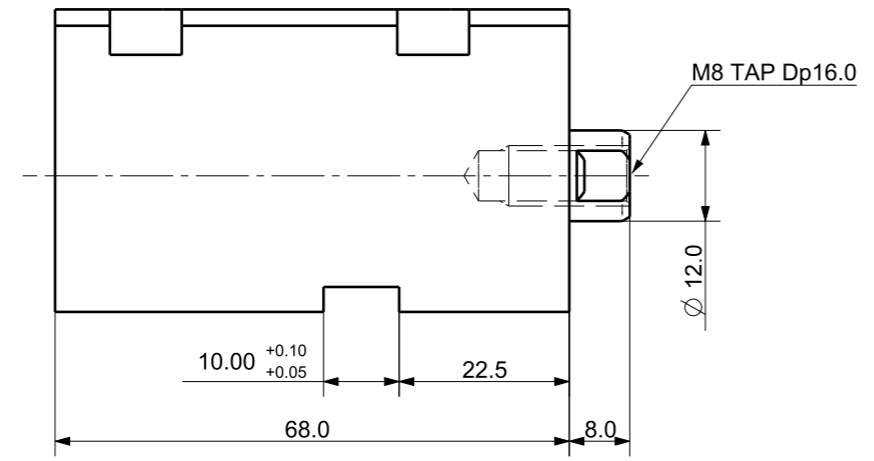
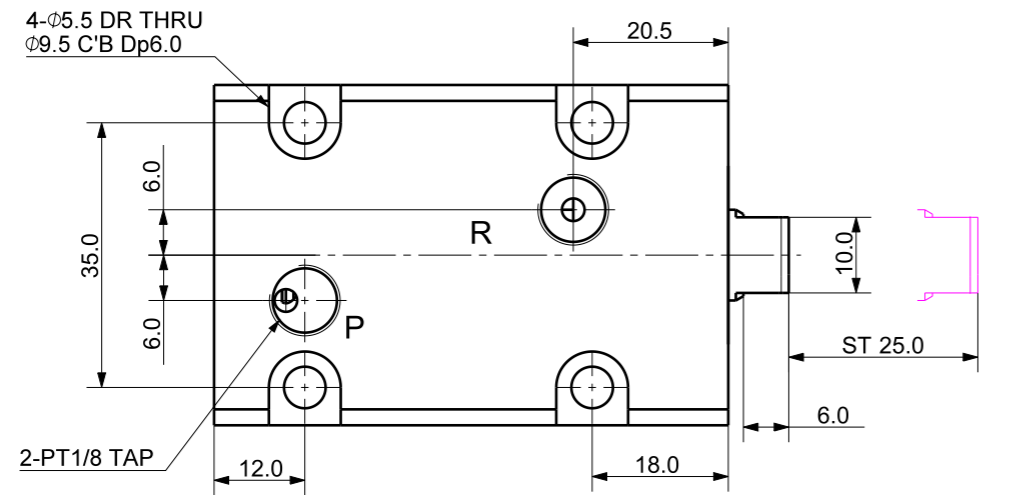

Isometric view (1:1)

| DET. NO | NAME | QTY | MAT'L | FINAL SIZES & PART No | REMARK |
|---------|------|-----|-------|-----------------------|--------|
| | | | | | |

| | | | | | |
|--|---------------|-------------|---|------|----------|
| UNLESS OTHERWISE SPECIFIED DIMENSIONS ARE IN MM ALL SURFACES 6.3S TOLERANCES ANGLE ± .X ± .XX ± 0.15 | SIGNATURES | MO-DA-YR |  케이제이에프(주) TOTAL CLAMPING SYSTEMS BLOCK CLAMP | | |
| | DRAWN | | | | |
| | CHECKED | | | | |
| | APPROVED | | | | |
| FINISH | WORK ORDER NO | REF DWG NO. | DWG NO. | A3 | |
| HEAT TREAT | | --- | BDH-2025_B | | |
| | | SCALE | TOOL | PART | SHEET OF |