

FILE NAME:

REVISIONS

ZONE	LTR	DESCRIPTION	DATE	APPROVED
------	-----	-------------	------	----------

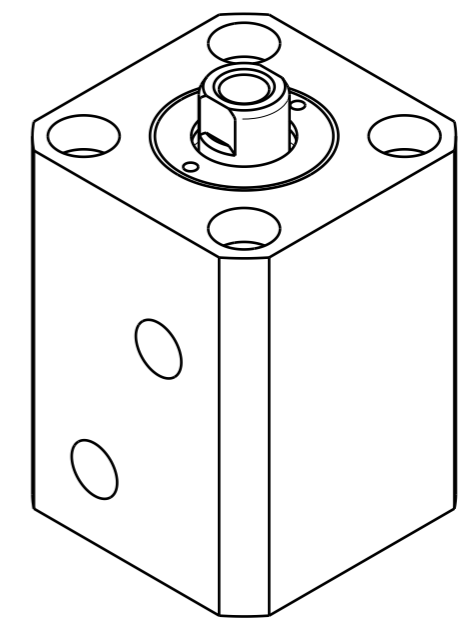
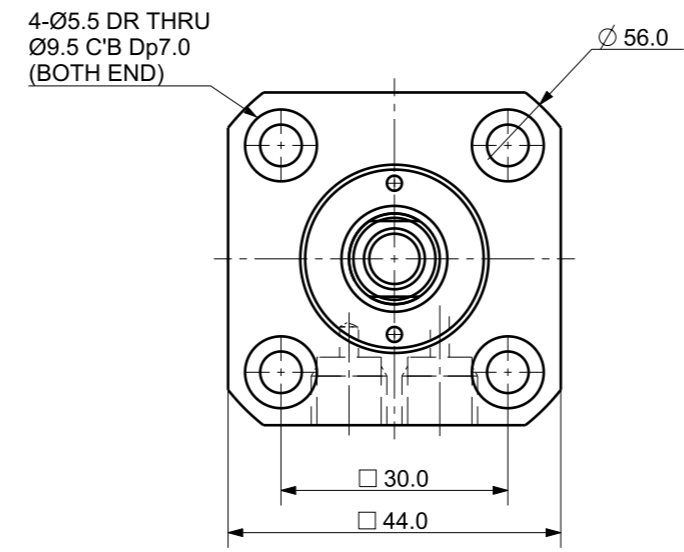
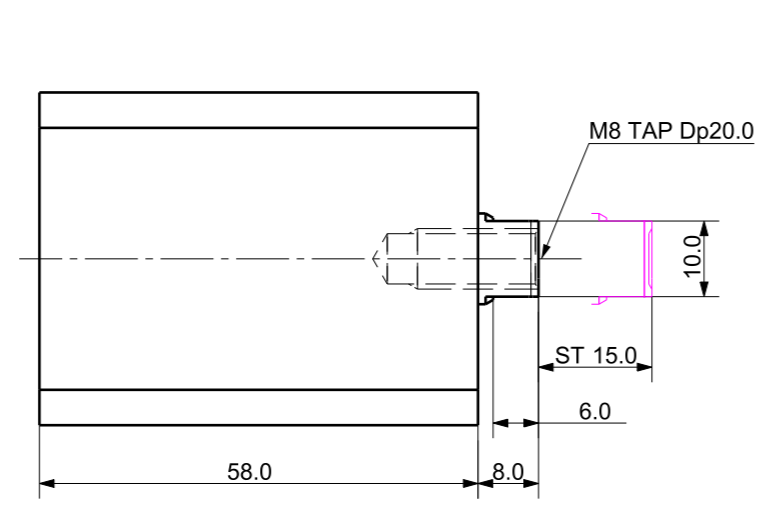

Isometric view (1:1)

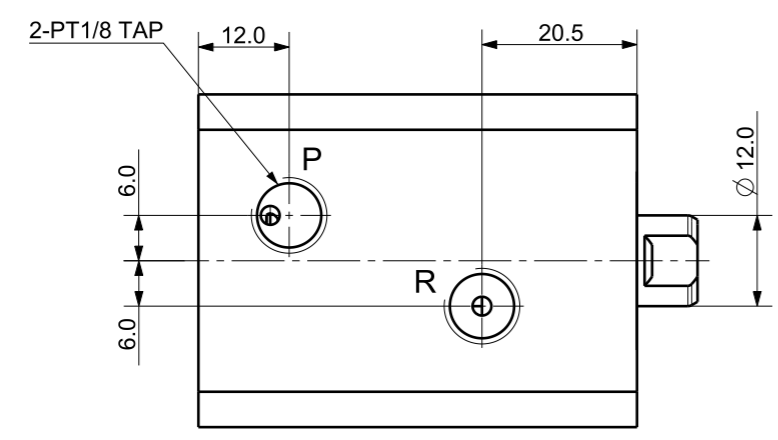

DET. NO	NAME	QTY	MAT'L	FINAL SIZES & PART No	REMARK
UNLESS OTHERWISE SPECIFIED		SIGNATURES		MO-DA-YR	
DIMENSIONS ARE IN MM		DRAWN		TITLE	
ALL SURFACES 6.3S		CHECKED		BLOCK CLAMP	
TOLERANCES		APPROVED		KJF 케이제이에프(주) TOTAL CLAMPING SYSTEMS	
ANGLE ±				REF DWG NO.	
X ±				DWG NO.	
.X ± 0.15				BDV-2015_B	
.XX ±		WORK ORDER NO		A3	
FINISH ----		REF DWG NO. ---		SCALE /	
HEAT TREAT ----		TOOL <input type="checkbox"/> PART <input type="checkbox"/> SHEET		OF	