

FILE NAME:

REVISIONS

ZONE	LTR	DESCRIPTION	DATE	APPROVED
------	-----	-------------	------	----------

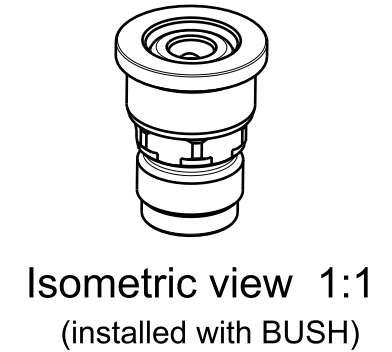
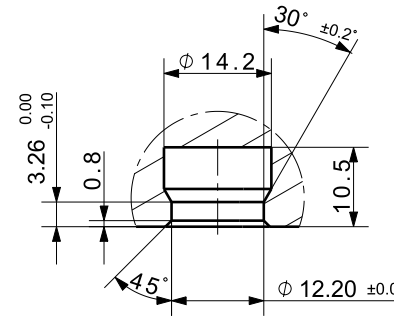
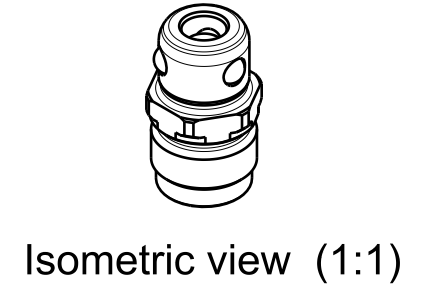
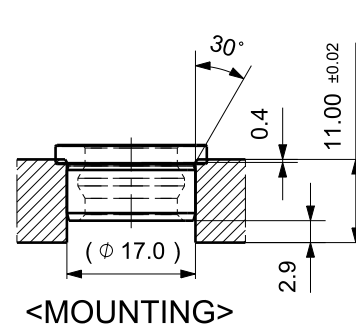
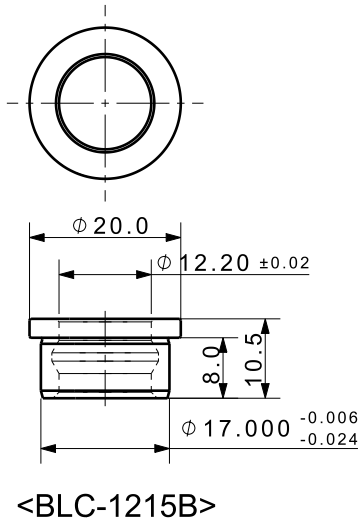
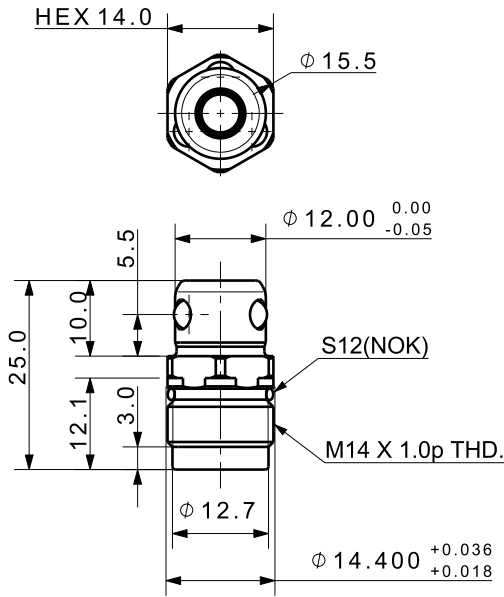

<Workpiece Hole Reference Dimensions>

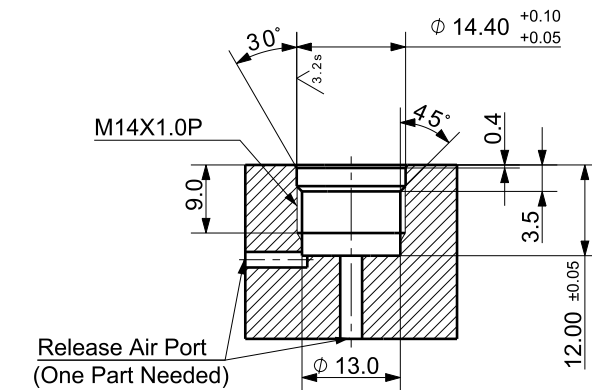

<MOUNTING DIMENSION>

DET.NO	NAME	Q'TY	MAT'L	FINAL SIZES & PART No	REMARK
--------	------	------	-------	-----------------------	--------

UNLESS OTHERWISE SPECIFIED	SIGNATURES	MO-DA-YR
DIMENSIONS ARE IN MM	DRAWN	
ALL SURFACES 6.3S	CHECKED	
TOLERANCES	APPROVED	
ANGLE ±		
.X ± 0.15		
.XX ± 0.05		
FINISH	WORK ORDER NO	REF DWG NO.
HEAT TREAT		DWG NO



케이제이에프(주)
TOTAL CLAMPING SYSTEMS

BALL LOCK CYLINDER

DWG NO
BLC-1215_C_DWG A4

SCALE / TOOL PART SHEET OF