

8 7 6 5 4 3 2 1

FILE NAME:

REVISIONS

ZONE	LTR	DESCRIPTION	DATE	APPROVED
------	-----	-------------	------	----------

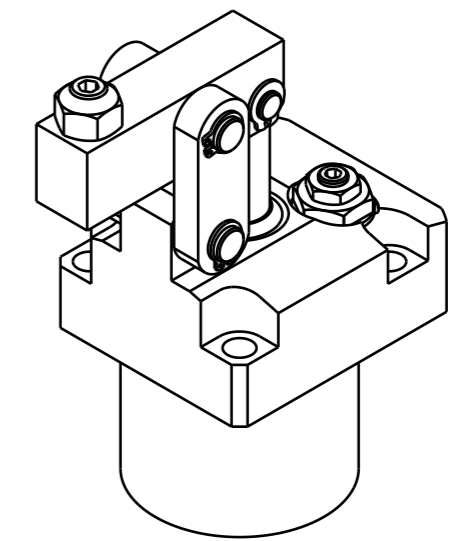
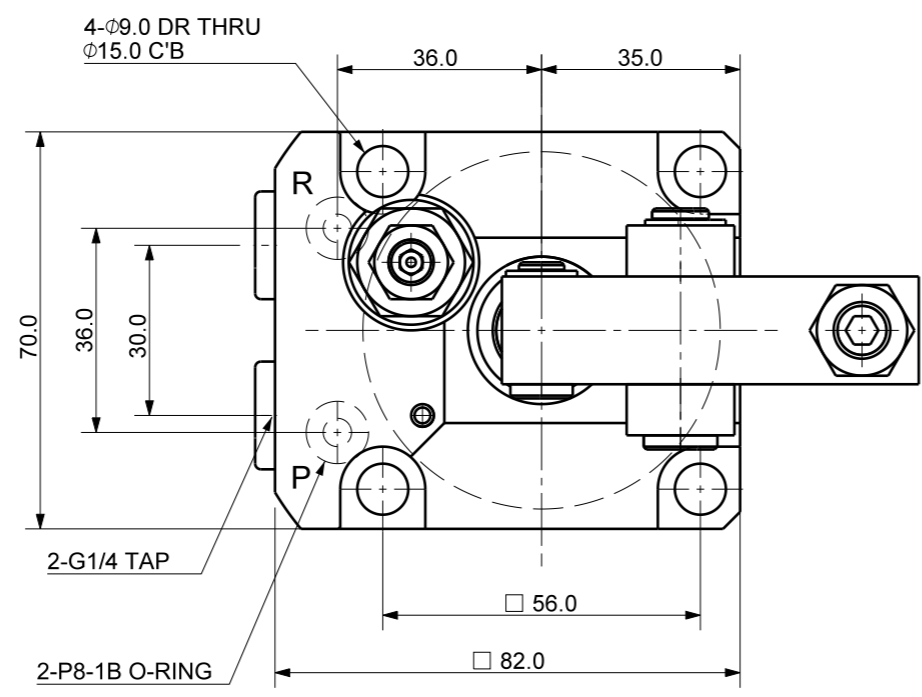

Isometric view (1:2)

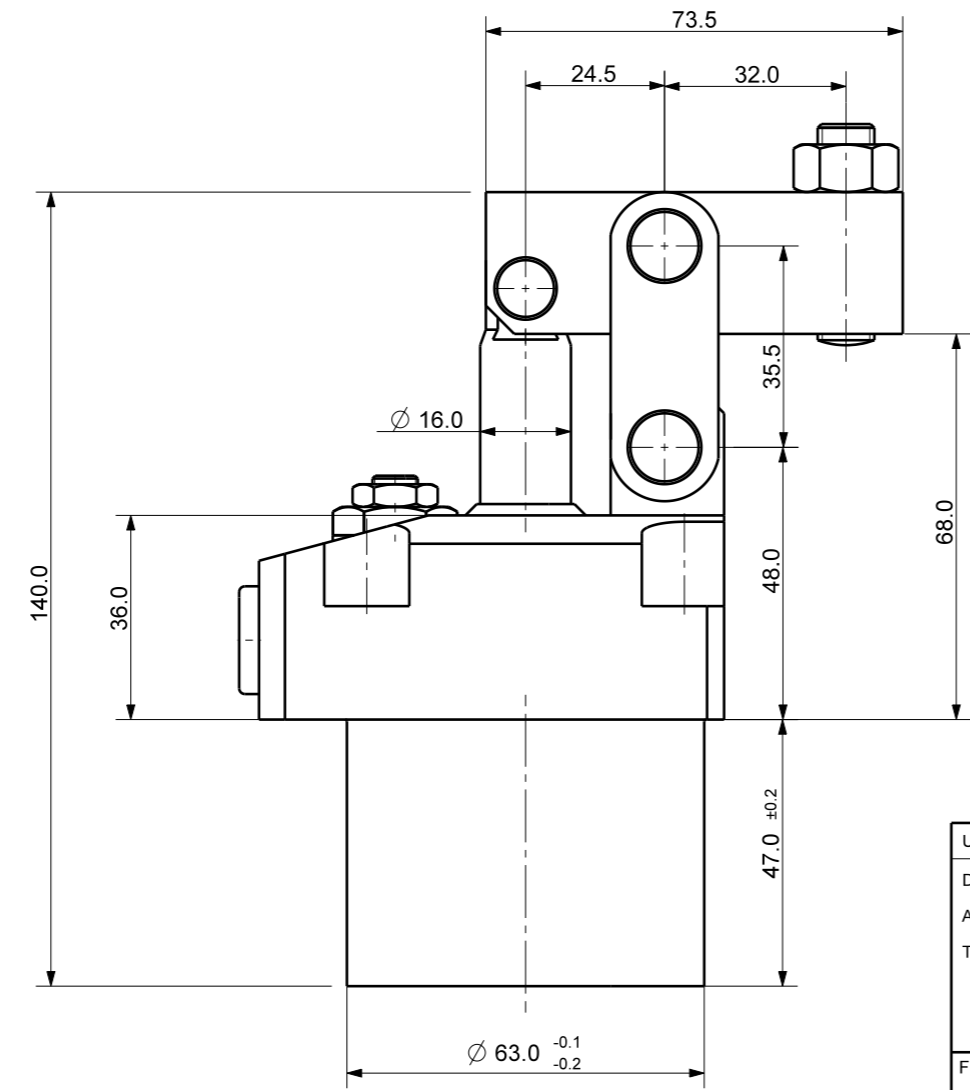
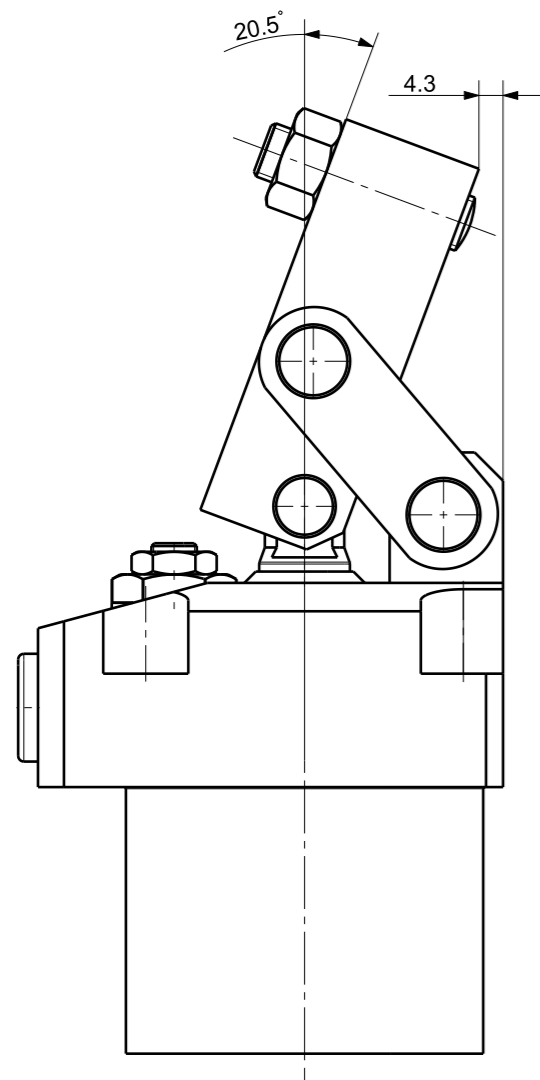

DET. NO	NAME	QTY	MAT'L	FINAL SIZES & PART No	REMARK

UNLESS OTHERWISE SPECIFIED	SIGNATURES	MO-DA-YR	 <b>케이제이에프(주)</b> TOTAL CLAMPING SYSTEMS			
DIMENSIONS ARE IN MM	DRAWN OK Y.S	06-01-17				
ALL SURFACES 6.3S	CHECKED					
TOLERANCES	APPROVED					
ANGLE			<b>HINGE CLAMP</b>			
X. ±						
.X ± 0.15			REF DWG NO.	DWG NO	A3	
.XX ±			---	CHGC-4463GVT_-		
FINISH	WORK ORDER NO	SCALE	TOOL	PART	SHEET	OF
BLOCK OXIDE		/	<input type="checkbox"/>	<input type="checkbox"/>		
HEAT TREAT						
HRC18~22						

8 7 6 5 4 3 2 1