

FILE NAME:

REVISIONS				
ZONE	LTR	DESCRIPTION	DATE	APPROVED

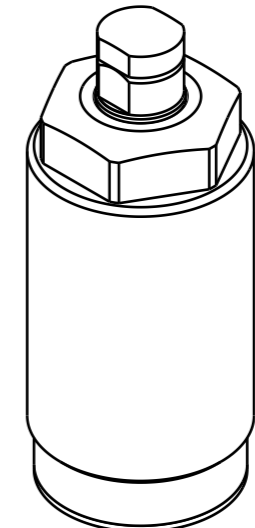

Isometric view (1:1)

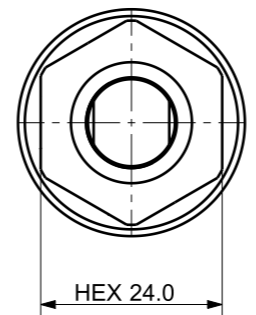
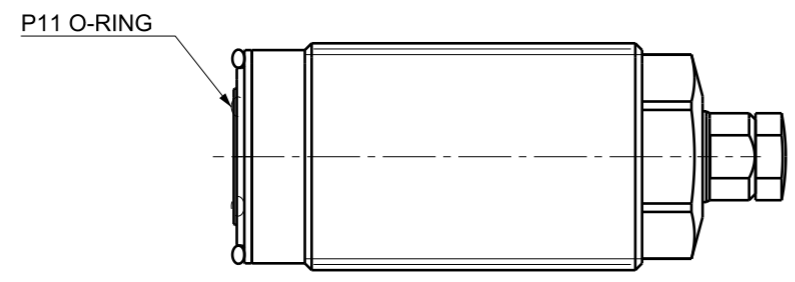
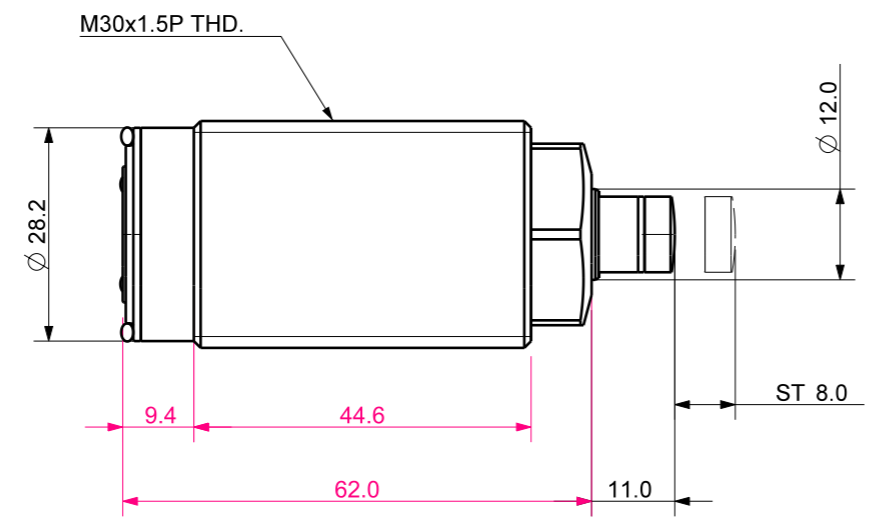

NOTE

1. MODEL No : CWS-12082
2. PLUNGER STROKE : 8.0 mm
3. OPERATING PRESSURE : 25 ~70 Kg/cm²
4. OPERATING TEMPERATYRE : 0 ~ 60°C
5. HYDRAULIC ADVANCE TYPE

DET.NO	NAME	QTY	MATL	FINAL SIZES & PART No	REMARK
--------	------	-----	------	-----------------------	--------

UNLESS OTHERWISE SPECIFIED	SIGNATURES	MO-DA-YR
DIMENSIONS ARE IN MM	DRAWN	
ALL SURFACES 6.3S	CHECKED	
TOLERANCES	APPROVED	
ANGLE ±		
.X ±		
.XX ± 0.15		
FINISH ---	WORK ORDER NO	
HEAT TREAT ---		

케이제이에프(주)
 TOTAL CLAMPING SYSTEMS

WORK SUPPORT

REF DWG NO. ---	DWG NO. CWS-12082_B	A3
SCALE /	TOOL <input type="checkbox"/> PART <input type="checkbox"/> SHEET	OF