

FILE NAME:

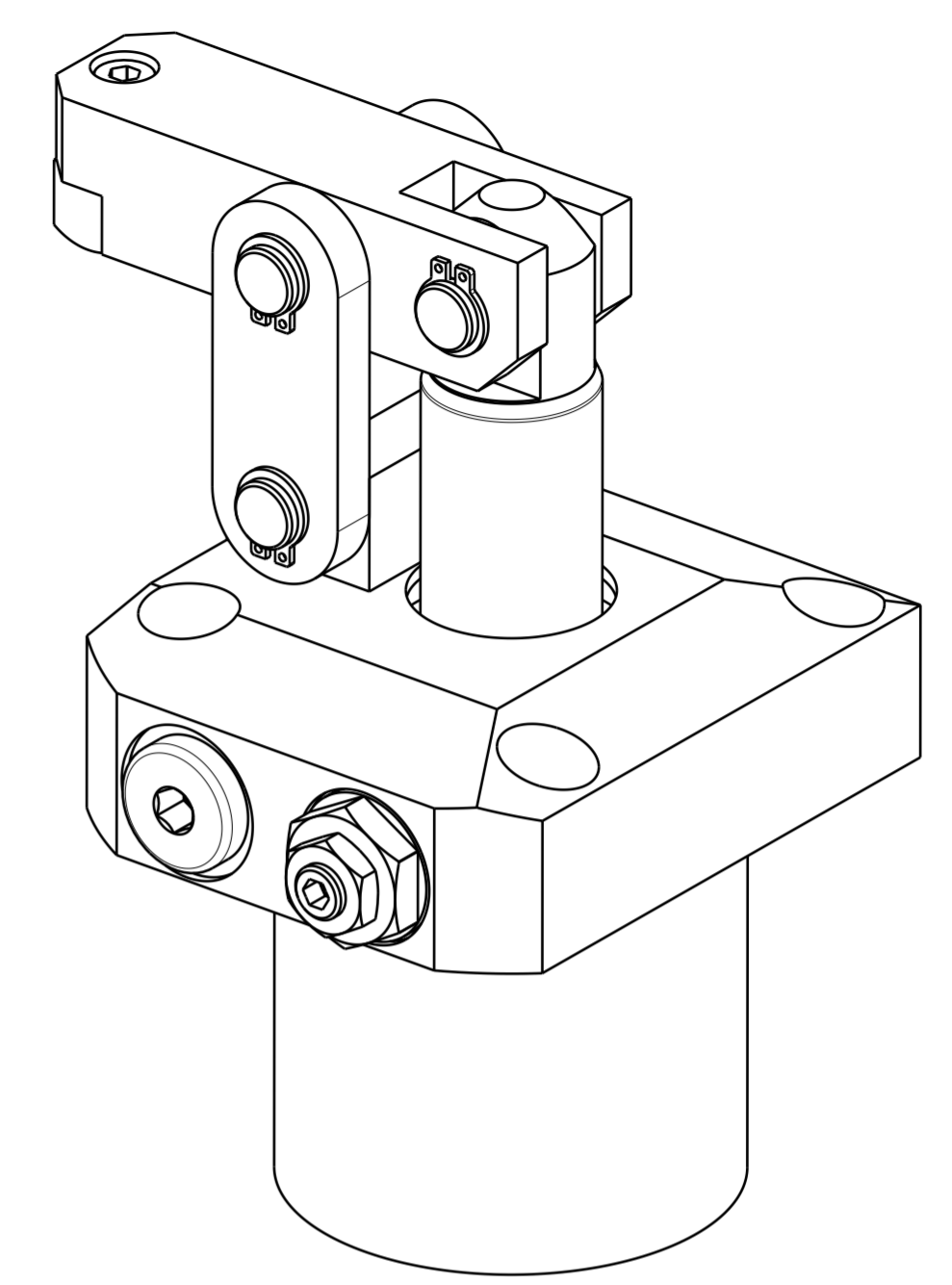

Isometric view (1:1)

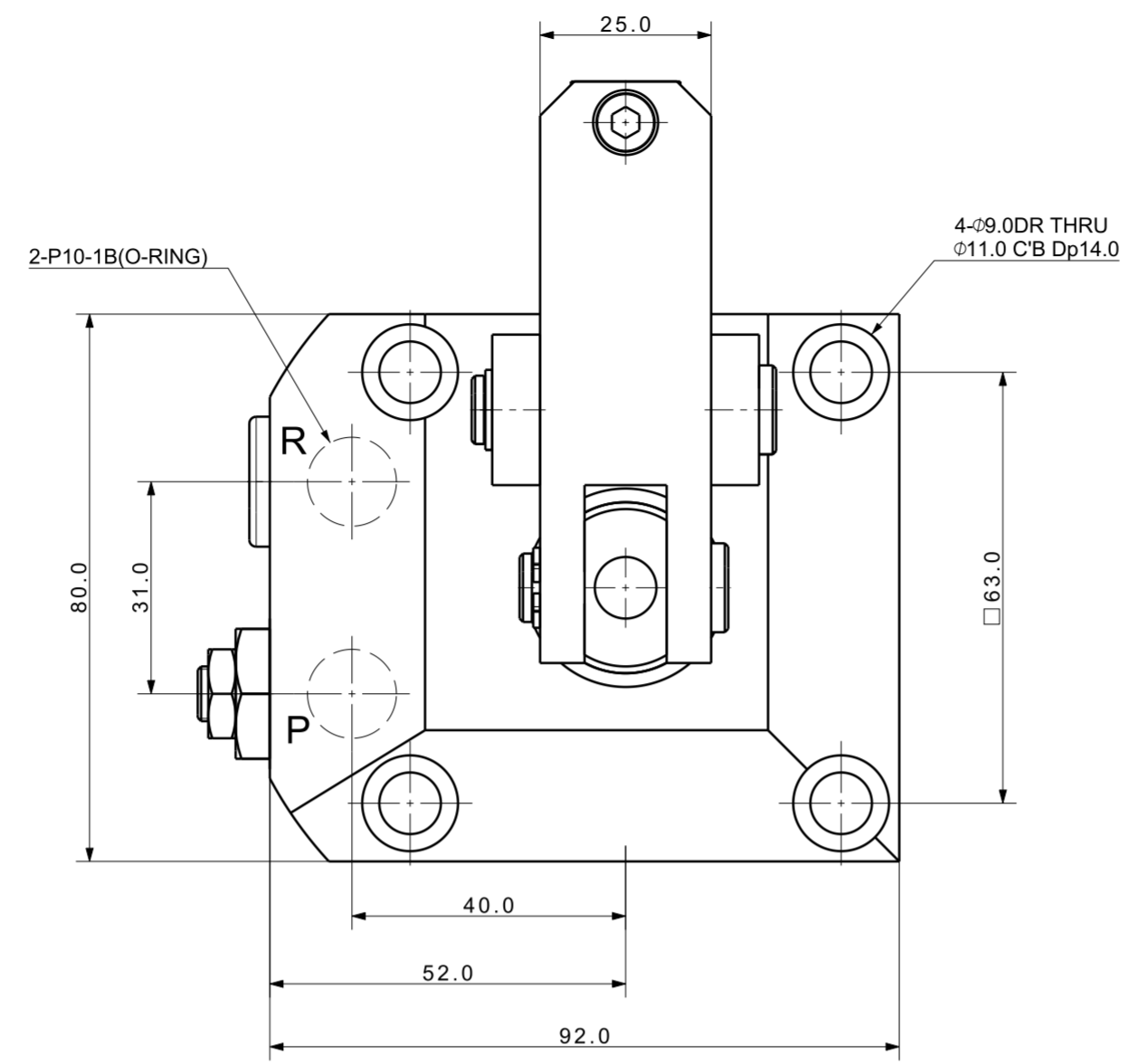
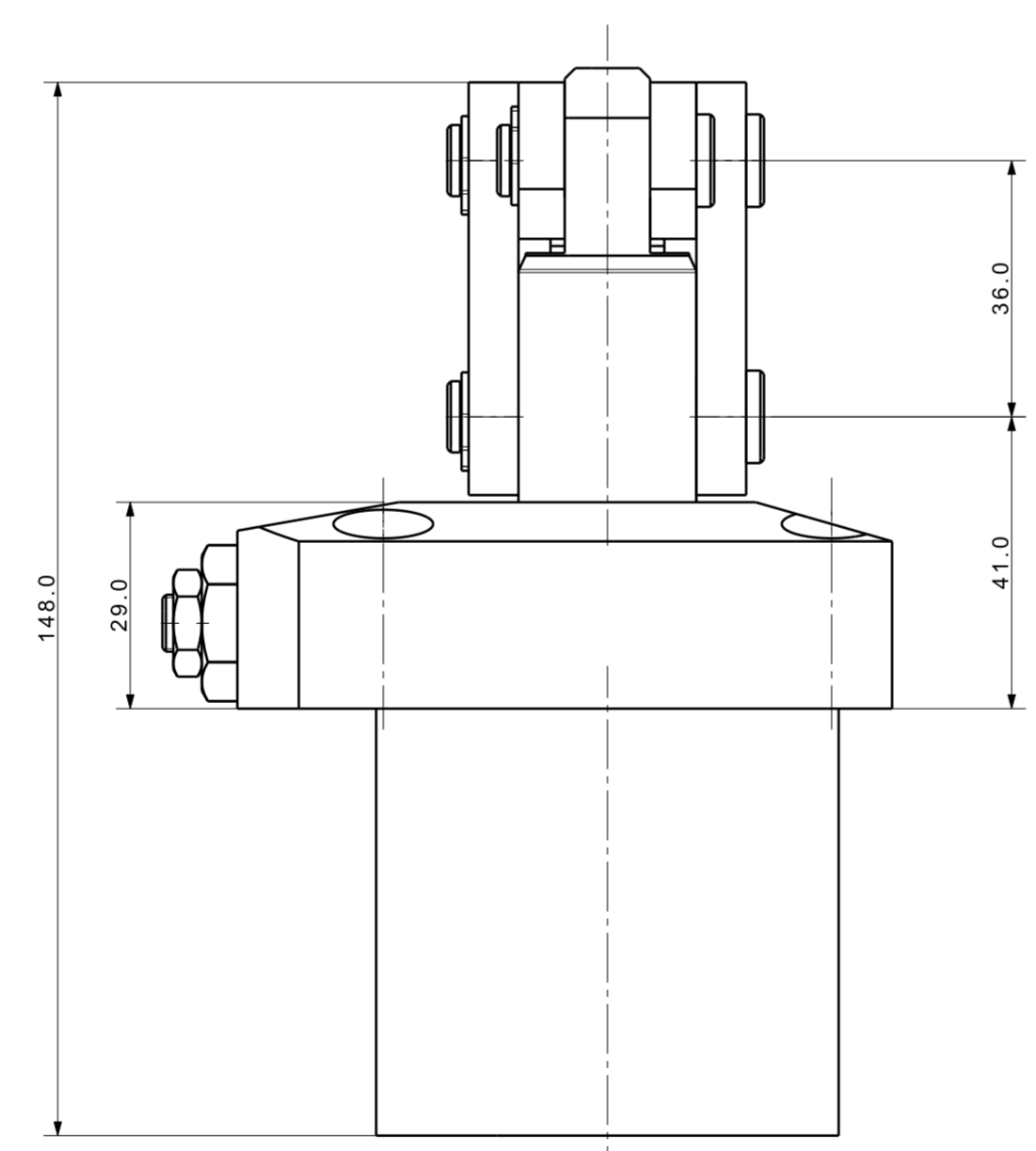
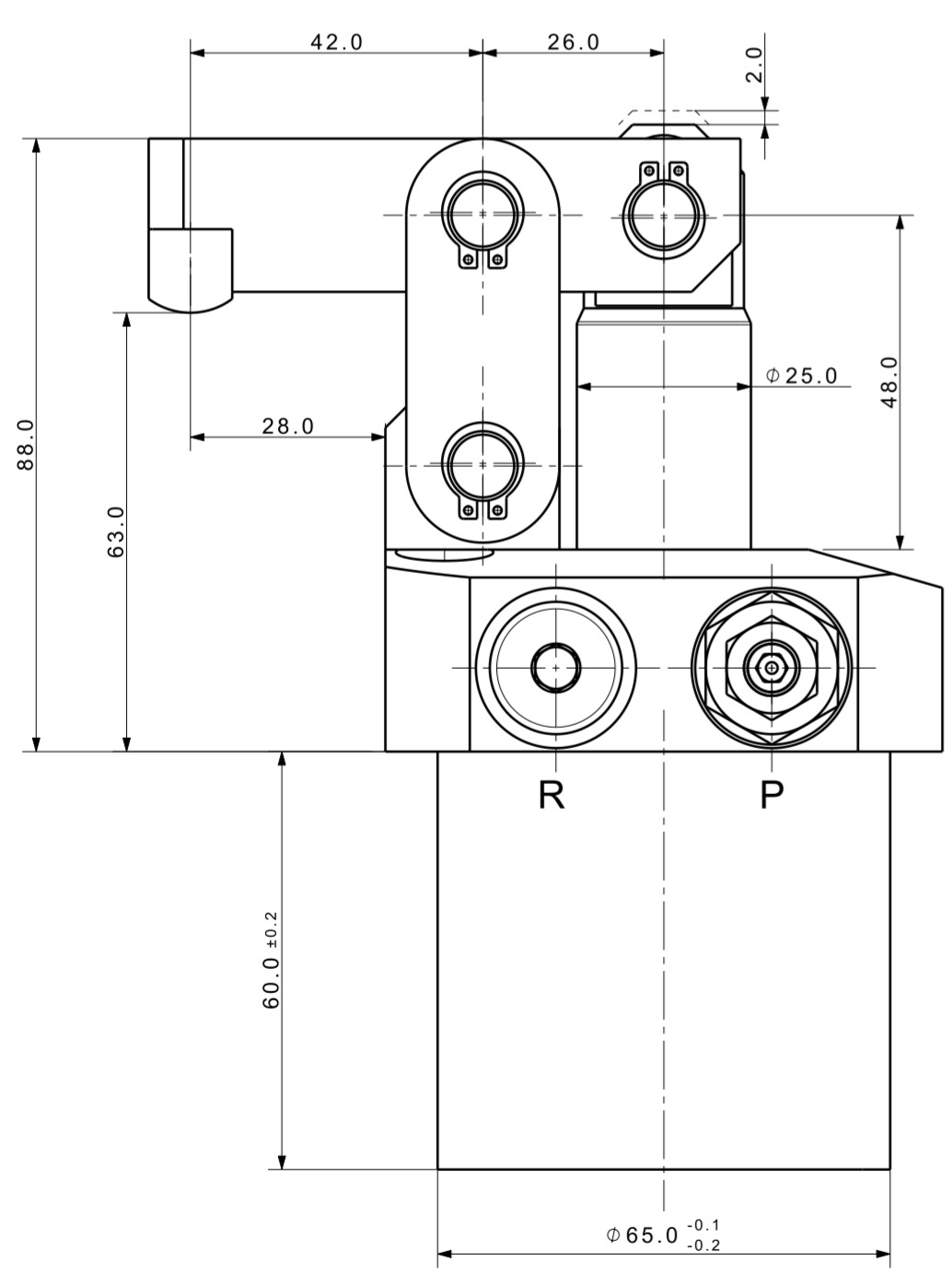

UNLESS OTHERWISE SPECIFIED DIMENSIONS ARE IN MM ALL SURFACES TOLERANCES ANGLE .X ± .X ± .XX ±	SIGNATURES		MO-DA-YR	(주)케이제이에프 TOTAL CLAMPING SYSTEMS
	DRAWN	---	00-00-00	
FINISH HEAT TREAT	WORK ORDER NO		REF DWG NO.	DWG NO
			-	HGC-4005GV-LH
			SCALE	TOOL <input type="checkbox"/> PART <input type="checkbox"/> SHEET <input type="checkbox"/> OF
				A2