

FILE NAME:

REVISIONS

ZONE	LTR	DESCRIPTION	DATE	APPROVED
------	-----	-------------	------	----------

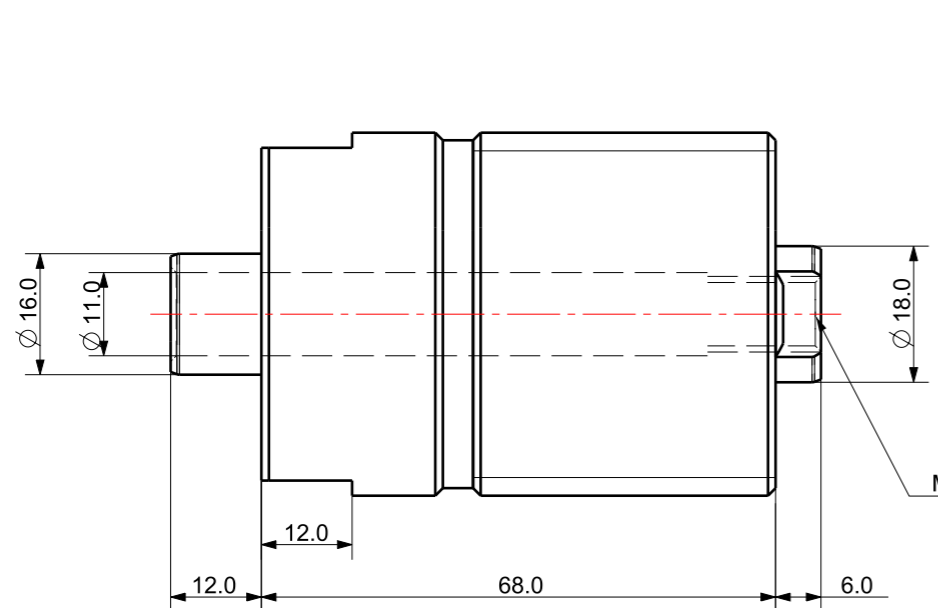

4-M6 TAP Dp15.0  
EQUAL SPACE  
PCD  $\phi$ 37.0

M10 x 1.5P TAP Dp15.0

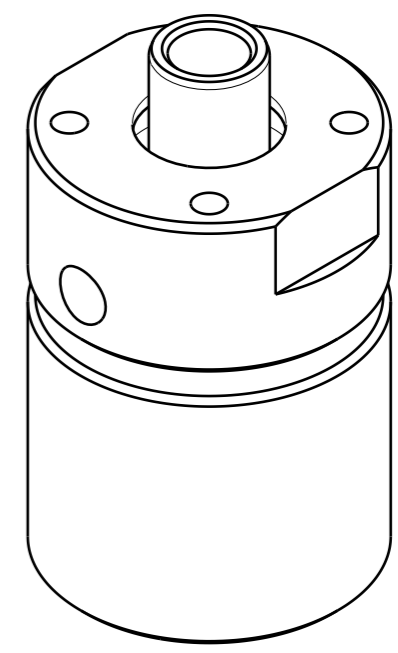
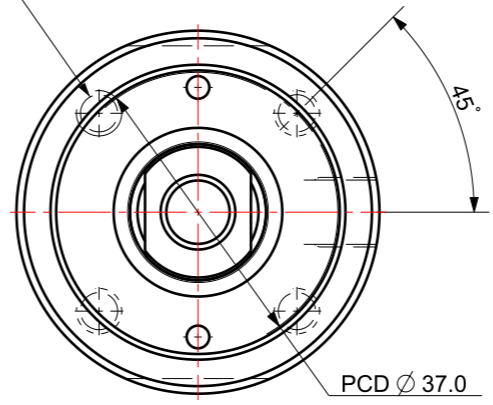

Isometric view (1:1)

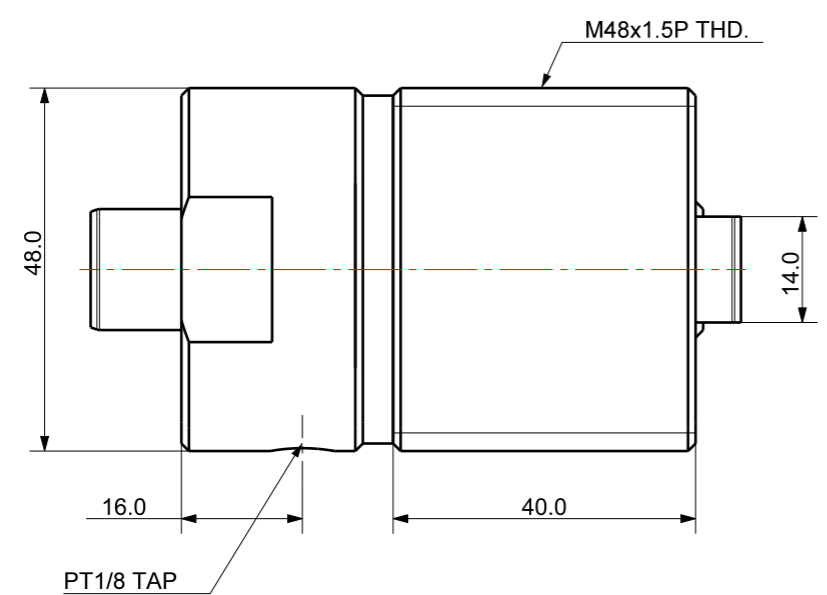

M48x1.5P THD.

PT1/8 TAP

DET. NO	NAME	QTY	MAT'L	FINAL SIZES & PART No	REMARK
UNLESS OTHERWISE SPECIFIED		SIGNATURES		MO-DA-YR	
DIMENSIONS ARE IN MM		DRAWN		TITLE	
ALL SURFACES 6.3S		CHECKED		HOLLOW PUSH CLAMP	
TOLERANCES		APPROVED		DWG NO. HLP-2808	
ANGLE		WORK ORDER NO. ---		SCALE	
X. $\pm$				TOOL <input type="checkbox"/> PART <input type="checkbox"/> SHEET <input type="checkbox"/> OF	
.X $\pm$ 0.15				A3	
.XX $\pm$					
FINISH		REF DWG NO.		DWG NO. HLP-2808	
HEAT TREAT					



HOLLOW PUSH CLAMP

HLP-2808

A3