

FILE NAME:

REVISIONS

ZONE	LTR	DESCRIPTION	DATE	APPROVED
------	-----	-------------	------	----------

4-φ4.5 HOLE THRU

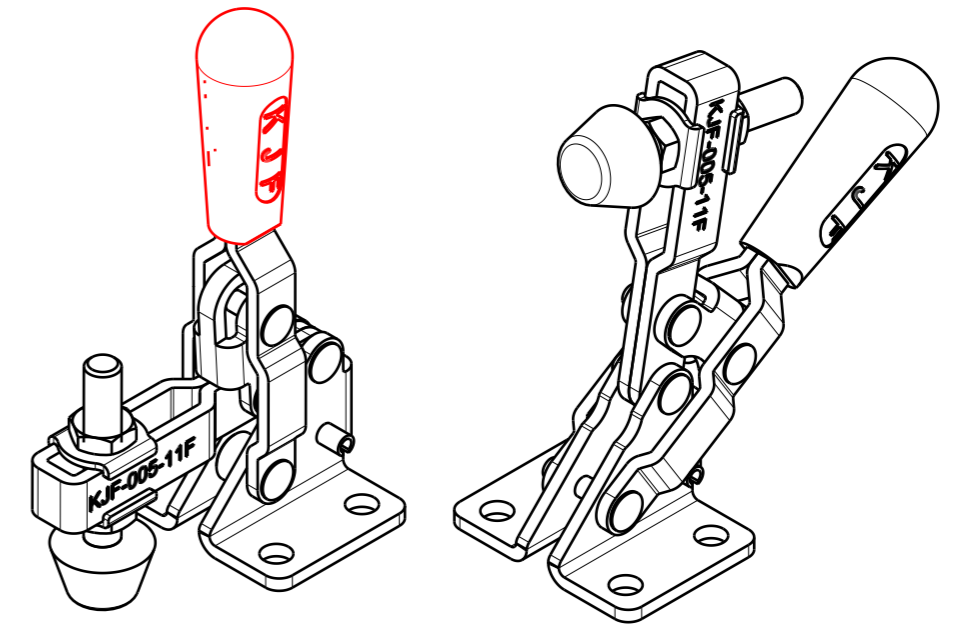
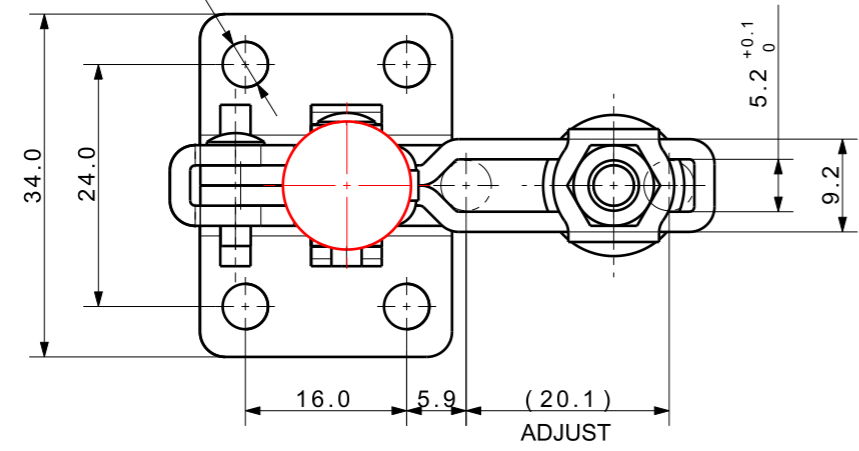

Isometric view (1:1)

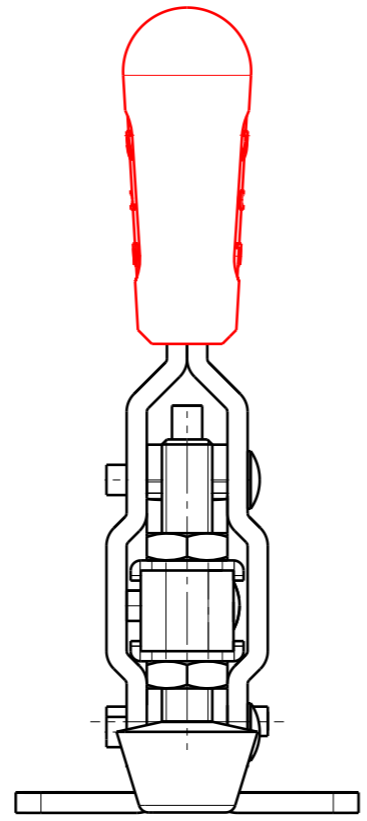
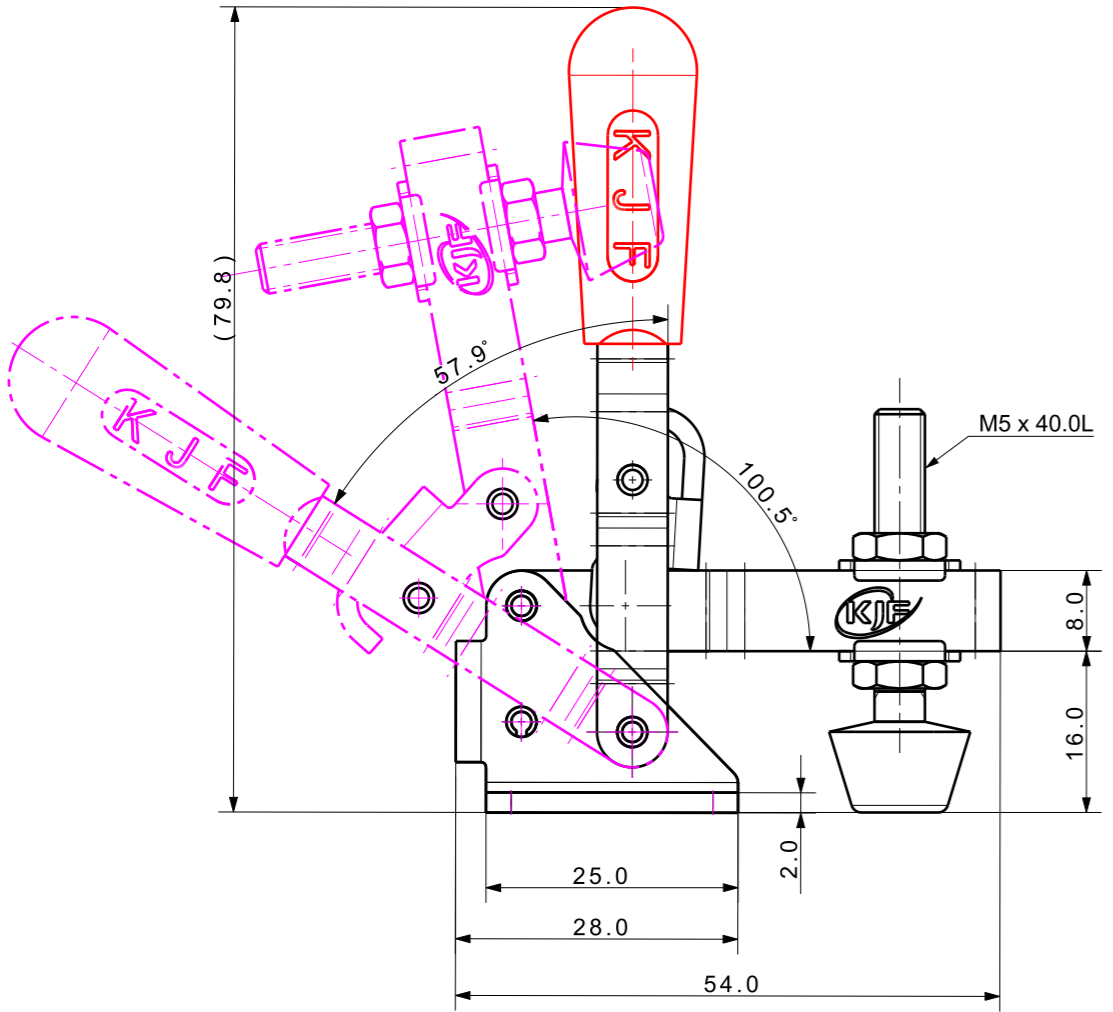

DET. NO	NAME	QTY	MAT'L	FINAL SIZES & PART No	REMARK
UNLESS OTHERWISE SPECIFIED		SIGNATURES		MO-DA-YR	
DIMENSIONS ARE IN MM		DRAWN		TITLE	
ALL SURFACES 6.3S		CHECKED		KJF 케이제이에프(주) TOTAL CLAMPING SYSTEMS	
TOLERANCES		APPROVED		TOGGLE CLAMP	
ANGLE		WORK ORDER NO		REF DWG NO.	
X ±				DWG NO	
.X ± 0.15				KJF- 005-11F_C_DWG	
.XX ±				SCALE 4/3	
FINISH				TOOL <input type="checkbox"/> PART <input type="checkbox"/> SHEET <input type="checkbox"/> OF	
HEAT TREAT				A3	