

FILE NAME:

REVISIONS

ZONE	LTR	DESCRIPTION	DATE	APPROVED
------	-----	-------------	------	----------

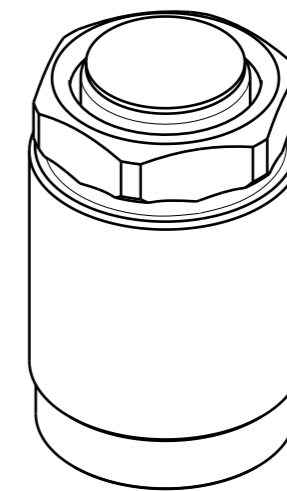
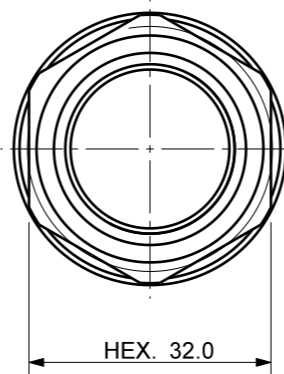
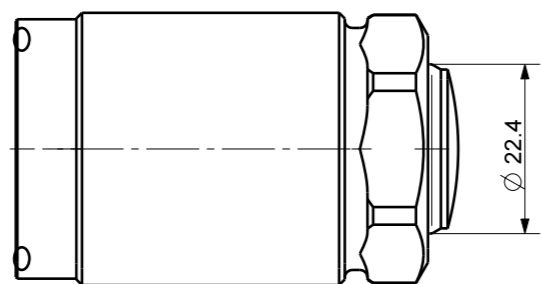

Isometric view (1:1)

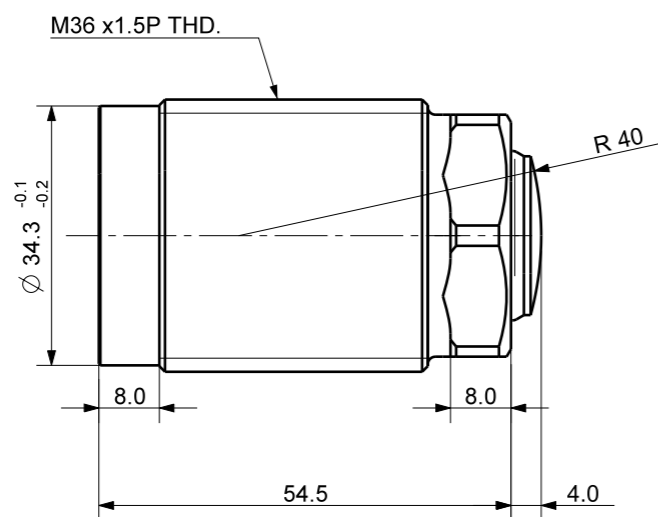

DET. NO	NAME	QTY	MAT'L	FINAL SIZES & PART No	REMARK
---------	------	-----	-------	-----------------------	--------

UNLESS OTHERWISE SPECIFIED	SIGNATURES	MO-DA-YR
DIMENSIONS ARE IN MM	DRAWN	
ALL SURFACES 6.3S	CHECKED	
TOLERANCES	APPROVED	
ANGLE		
X. ±		
.X ± 0.15		
.XX ±		
FINISH	WORK ORDER NO	
HEAT TREAT		

 케이제이에프(주) TOTAL CLAMPING SYSTEMS	
MANIFOLD TYPE THD. BODY CLAMP	
REF DWG NO. CMC 10	DWG NO. MTB-2215R
SCALE	TOOL <input type="checkbox"/> PART <input type="checkbox"/> SHEET <input type="checkbox"/> OF

A3