

REVISIONS

ZONE	LTR	DESCRIPTION	DATE	APPROVED

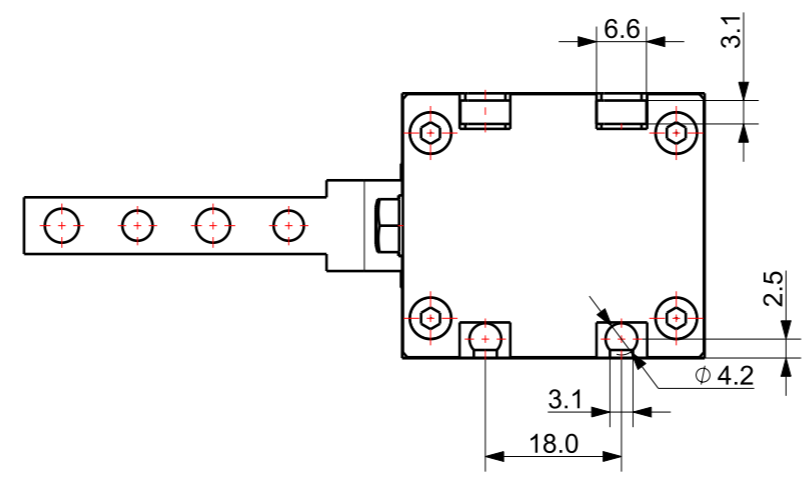

View A (1:1)
MAGNET SENSOR DETAIL

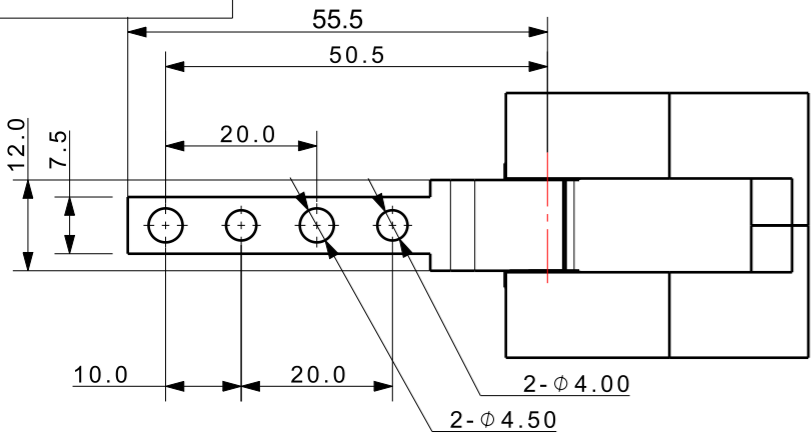
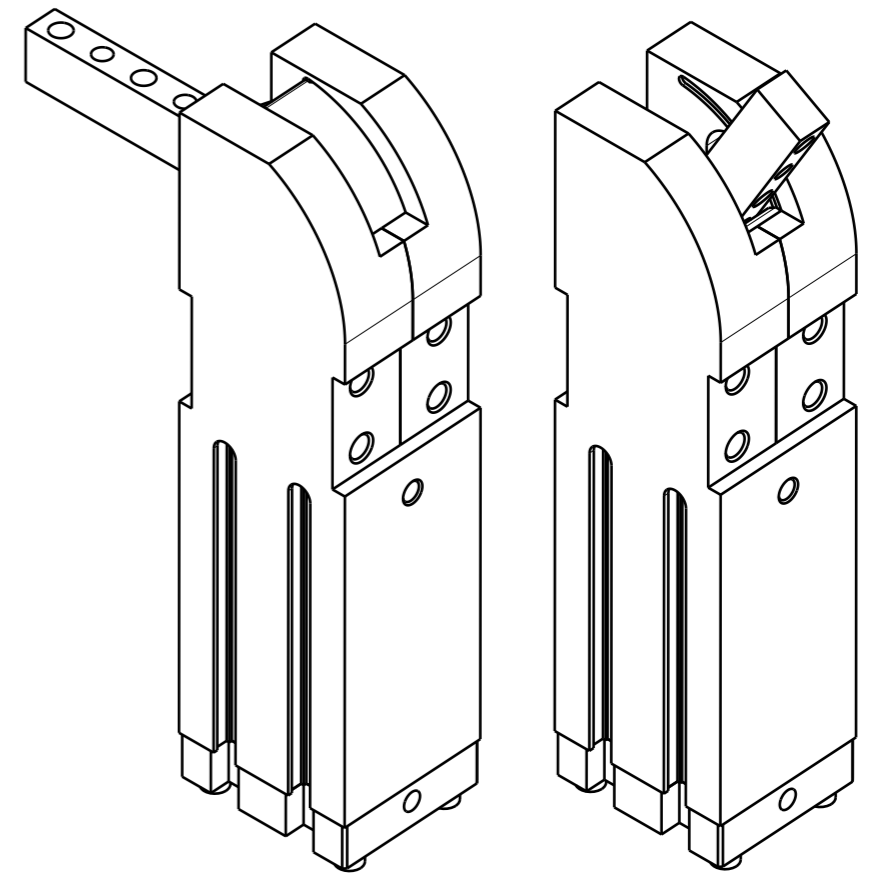

Isometric view 3:4

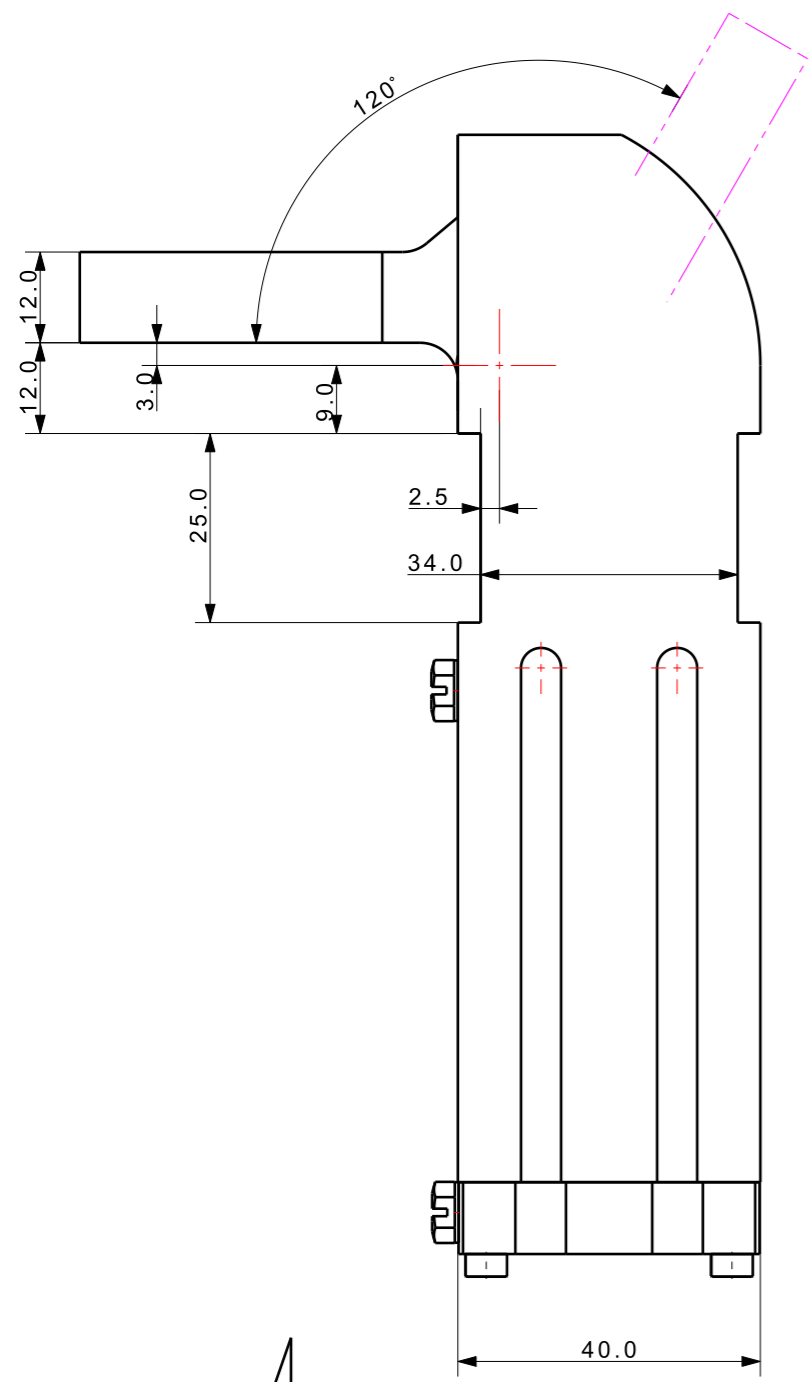

"A"

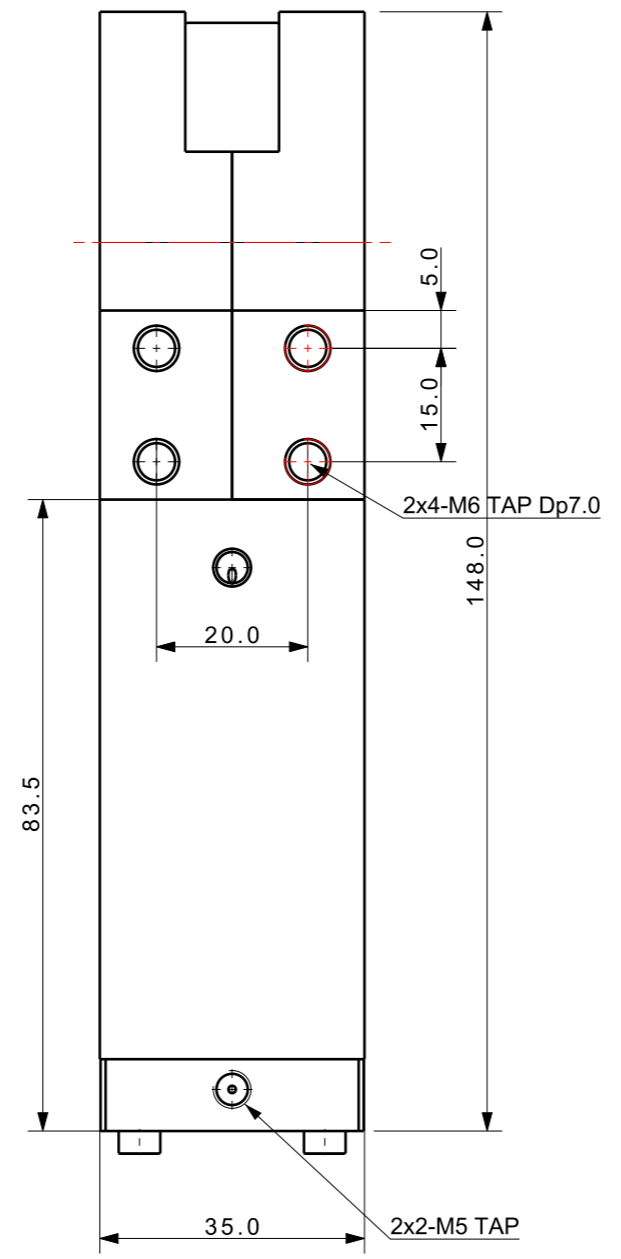

- NOTE
1. CYLINDER IN DIA : $\phi 26.0$
 2. ROD DIA : $\phi 10.0$
 3. CLAMP STROKE = 38.5 mm
 4. TOTAL STROKE = 39.5 mm

DET.NO	NAME	QTY	MATL	FINAL SIZES & PART No	REMARK	
UNLESS OTHERWISE SPECIFIED	SIGNATURES	MO-DA-YR				
DIMENSIONS ARE IN MM	DRAWN SSS	12-02-22				
ALL SURFACES 6.3S	CHECKED					
TOLERANCES	APPROVED					
ANGLE			POWER AIR CLAMP			
X. ±						
.X ± 0.15						
.XX ±						
FINISH	WORK ORDER NO	REF DWG NO.	DWG NO	PAC-2626AE_- _DWG A3		
HEAT TREAT						
		SCALE	TOOL	PART	SHEET	OF