

FILE NAME:

REVISIONS

ZONE	LTR	DESCRIPTION	DATE	APPROVED
------	-----	-------------	------	----------

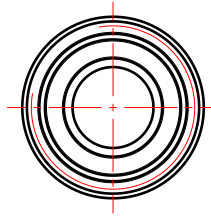

# COUNTERBALANCE SLEEVE

X-AXIS DIS'P : 0.1mm

Y-AXIS DIS'P : 0.1mm

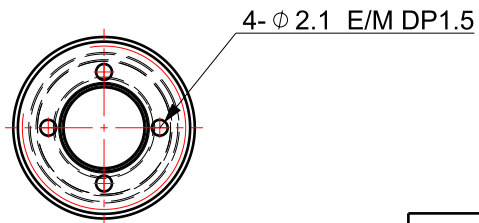
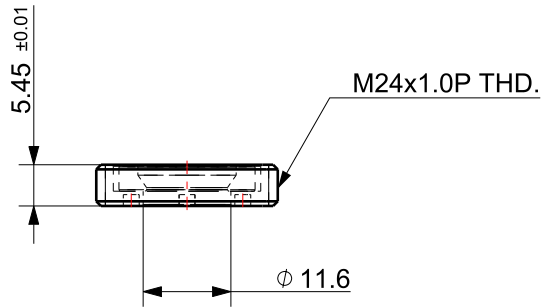

DET.NO	NAME	Q'TY	MAT'L	FINAL SIZES & PART No	REMARK
--------	------	------	-------	-----------------------	--------

UNLESS OTHERWISE SPECIFIED	SIGNATURES	MO-DA-YR
DIMENSIONS ARE IN MM	DRAWN ---	00-00-00
ALL SURFACES 6.3S	CHECKED	
TOLERANCES	APPROVED	
ANGLE ±		
X. ±		
.X ± 0.15		
.XX ± 0.05		
FINISH	WORK ORDER NO	REF DWG NO.
HEAT TREAT		DWG NO



케이제이에프(주)  
TOTAL CLAMPING SYSTEMS

TITLE
<b>COUNTERBALANCE SLEEVE</b>

REF DWG NO.	DWG NO	A4
---	PHS-2400_DWG	
SCALE /	TOOL <input type="checkbox"/> PART <input type="checkbox"/> SHEET	OF