

FILE NAME:

REVISIONS				
ZONE	LTR	DESCRIPTION	DATE	APPROVED

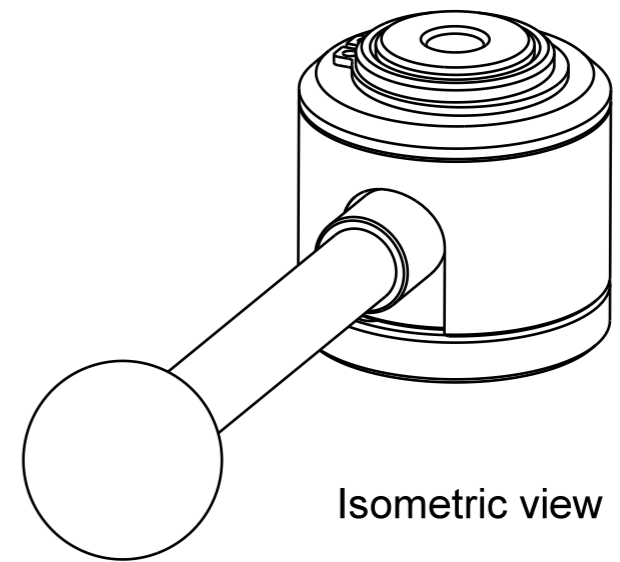

Isometric view (3:4)

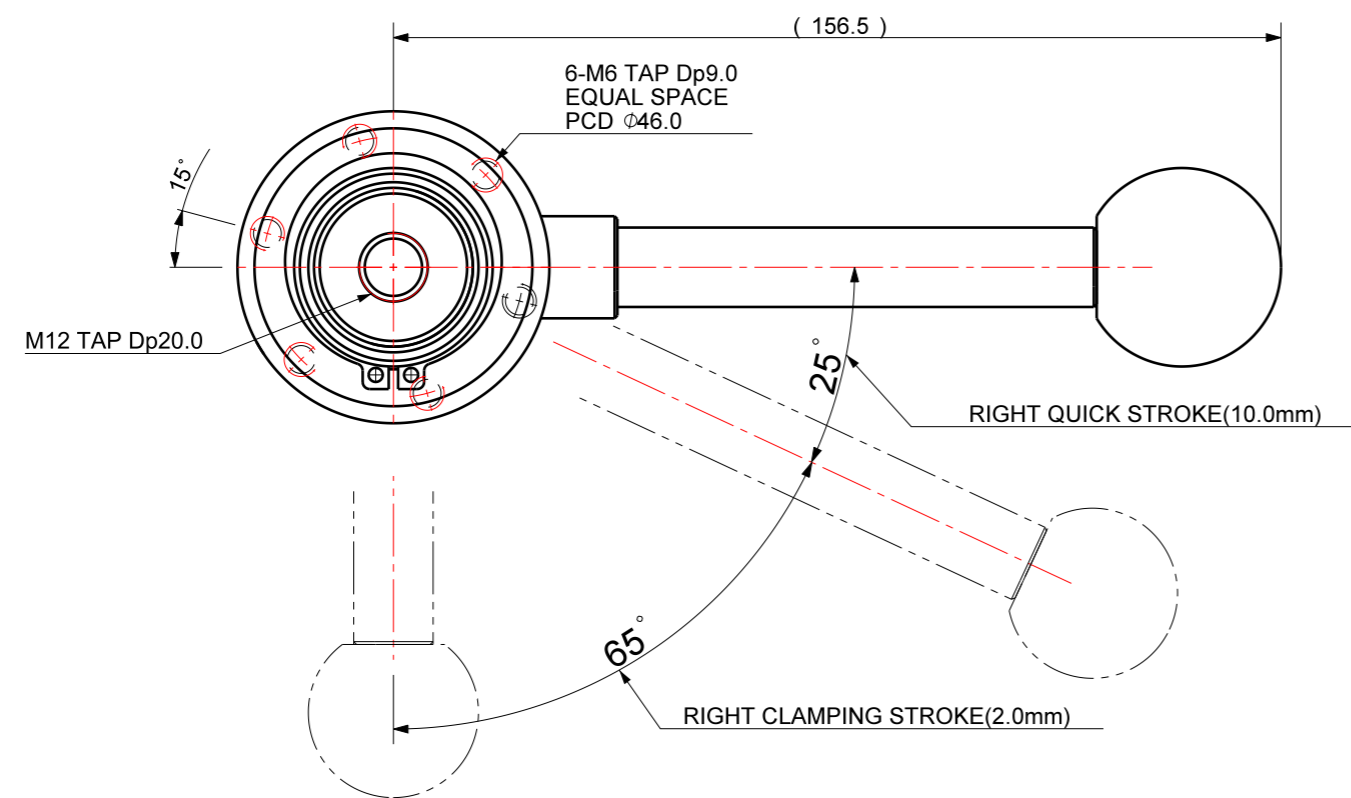
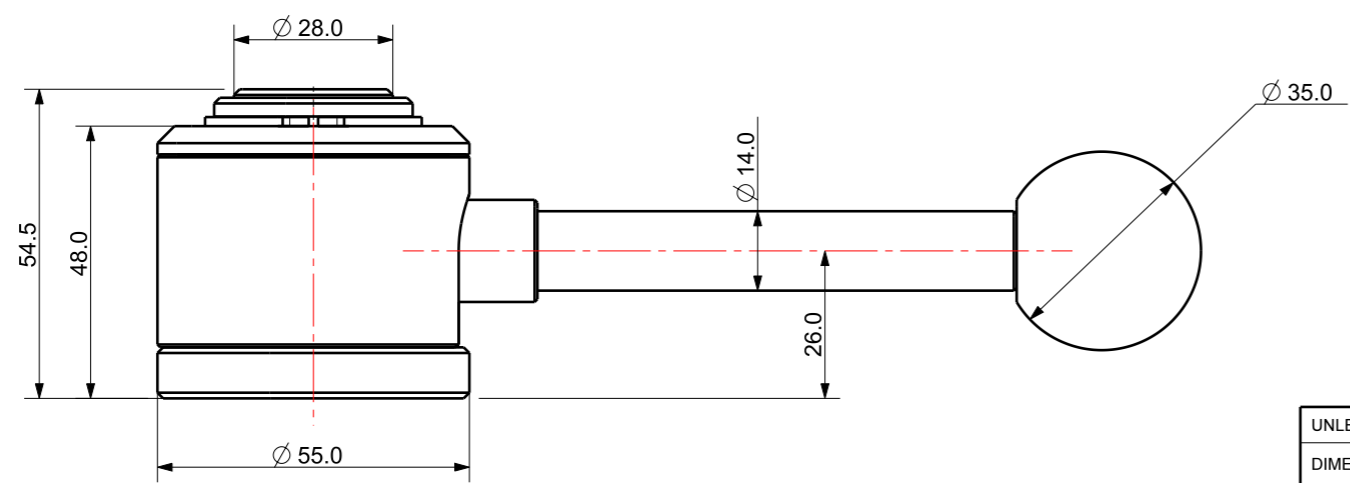

DET. NO	NAME	QTY	MAT'L	FINAL SIZES & PART No	REMARK

UNLESS OTHERWISE SPECIFIED	SIGNATURES	MO-DA-YR	 케이제이에프(주) TOTAL CLAMPING SYSTEMS		
DIMENSIONS ARE IN MM	DRAWN				
ALL SURFACES 6.3S	CHECKED				
TOLERANCES	APPROVED				
ANGLE			TITLE		
X. ±			QUICK ACTION CLAMP		
.X ± 0.15			REF DWG NO.		
.XX ±			DWG NO.		
FINISH	WORK ORDER NO		---	QAR-0512	A3
HEAT TREAT			SCALE	TOOL <input type="checkbox"/> PART <input type="checkbox"/> SHEET	OF