

FILE NAME:

REVISIONS

ZONE	LTR	DESCRIPTION	DATE	APPROVED
------	-----	-------------	------	----------

2-P5 O-RING

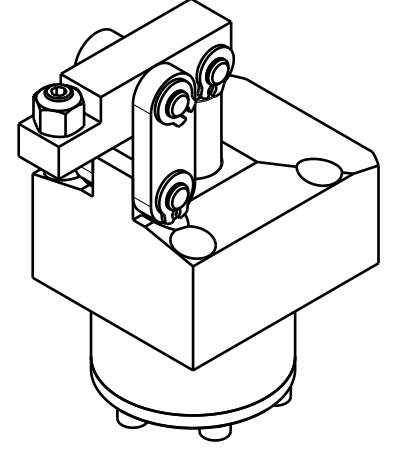
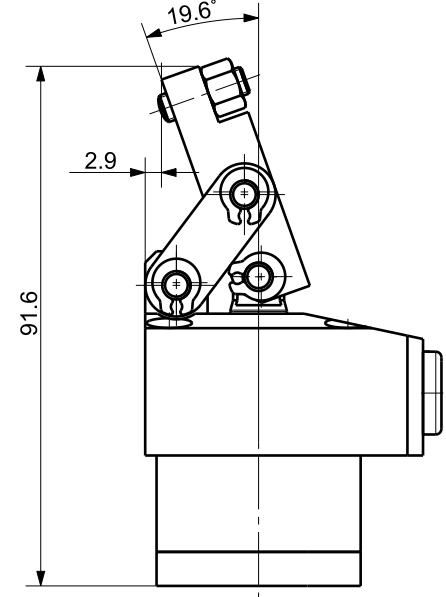
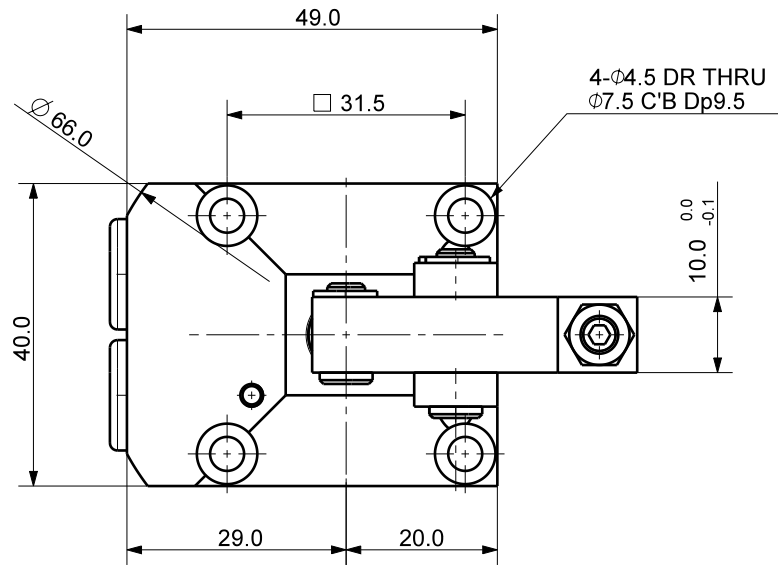
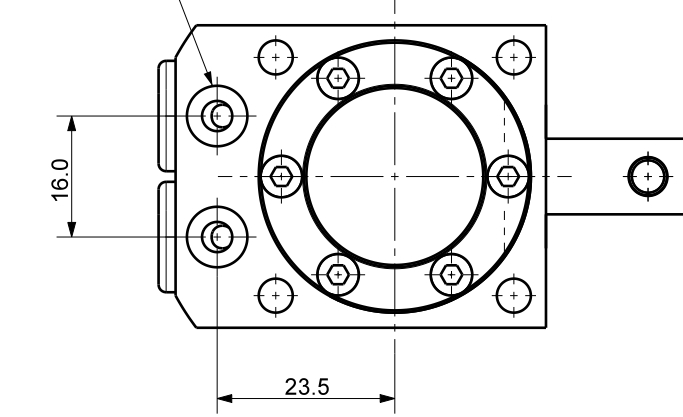

Isometric view (3:4)

2-G1/8 TAP

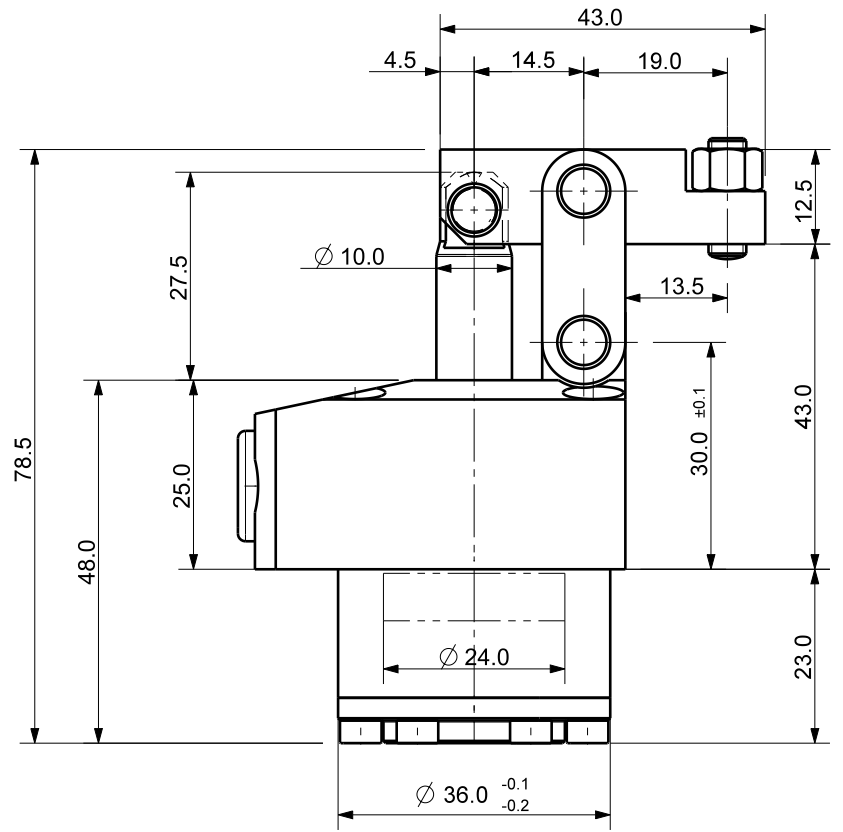
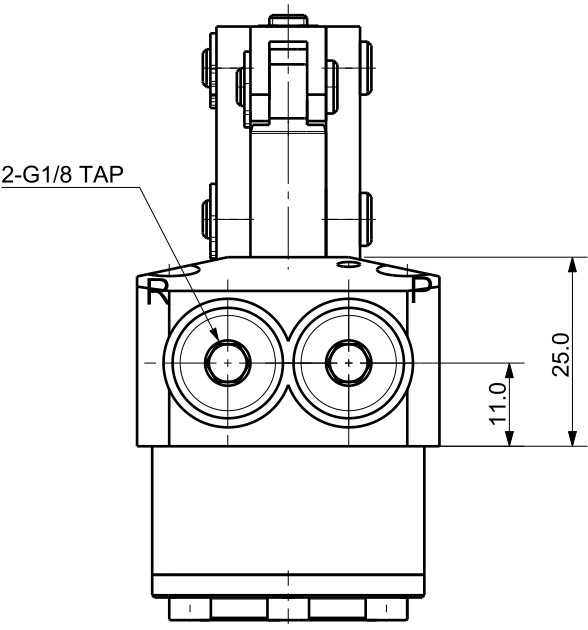

DET. NO	NAME	QTY	MAT'L	FINAL SIZES & PART No	REMARK
UNLESS OTHERWISE SPECIFIED		SIGNATURES		MO-DA-YR	
DIMENSIONS ARE IN MM		DRAWN		TITLE	
ALL SURFACES 6.3S		CHECKED		KJF 케이제이에프(주) TOTAL CLAMPING SYSTEMS	
TOLERANCES		APPROVED		HINGE CLAMP	
ANGLE ±		WORK ORDER NO		REF DWG NO.	
X ±		DWG NO		QHGC-2436G_-	
.X ± 0.15		SCALE		A3	
.XX ±		TOOL <input type="checkbox"/> PART <input type="checkbox"/> SHEET <input type="checkbox"/> OF			
FINISH					
HEAT TREAT					