

FILE NAME:

REVISIONS

ZONE	LTR	DESCRIPTION	DATE	APPROVED
△				

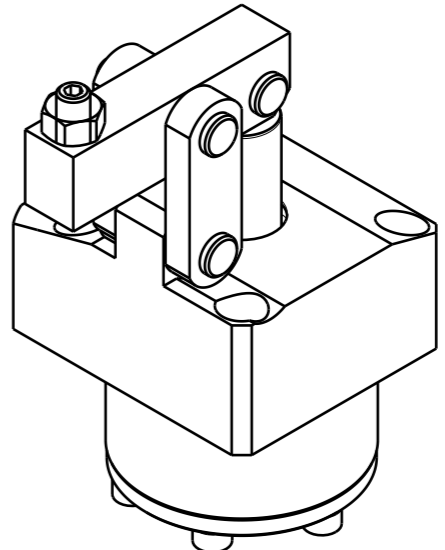
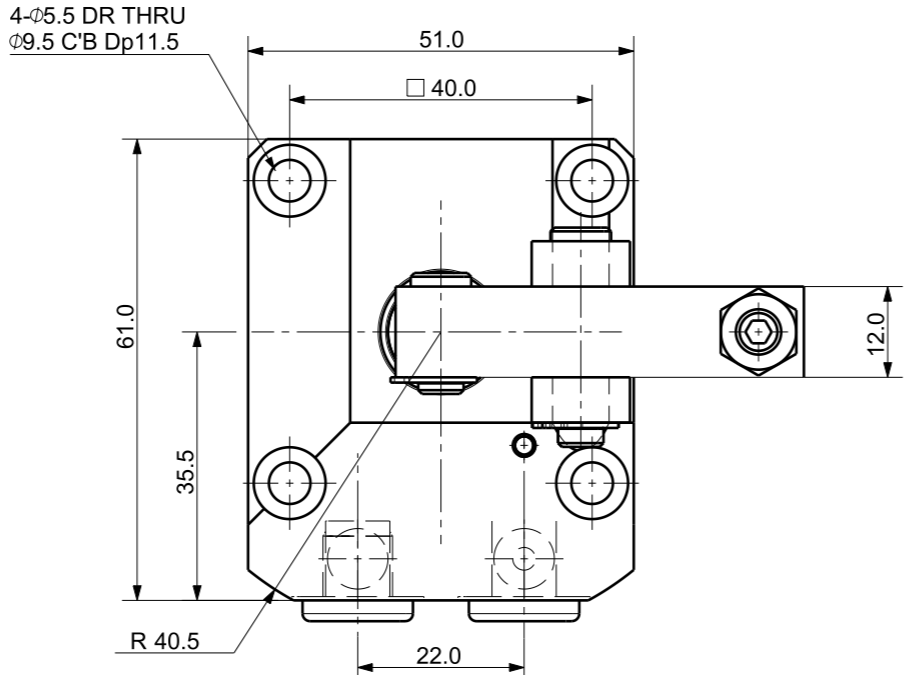
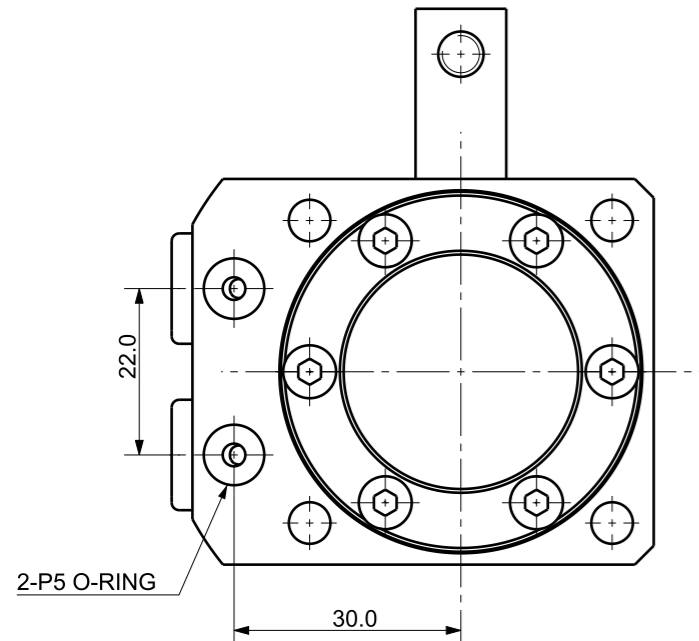

Isometric view (3:4)

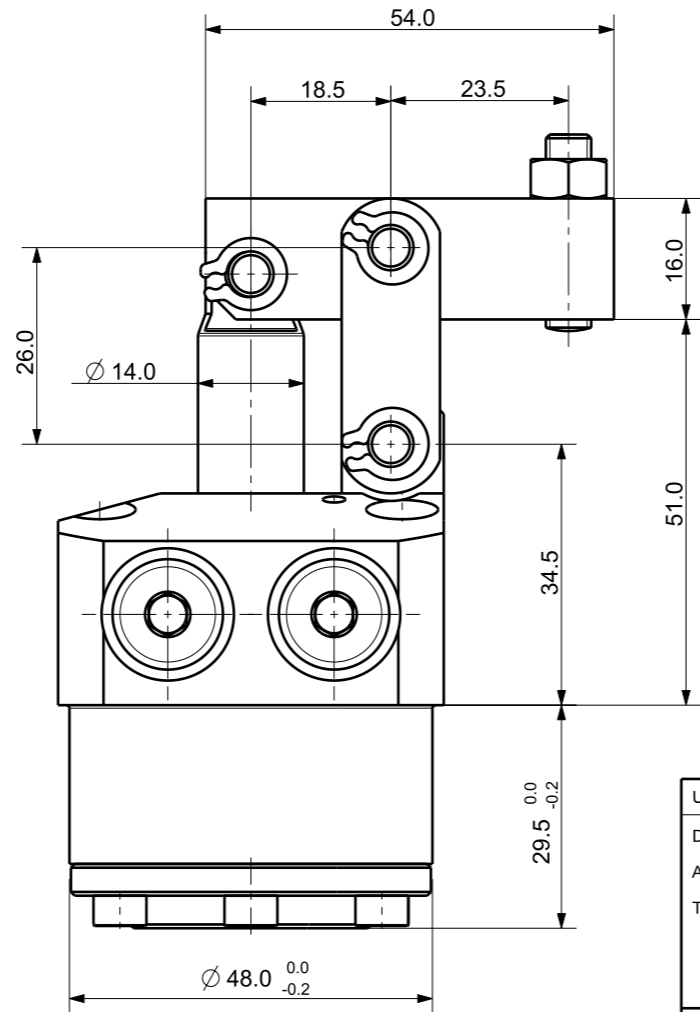
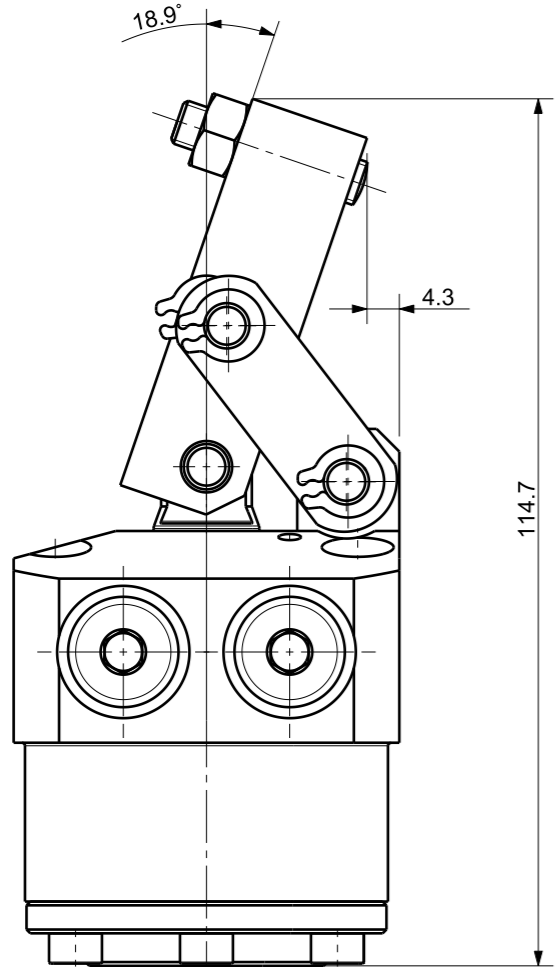

DET. NO	NAME	QTY	MATL	FINAL SIZES & PART No	REMARK
UNLESS OTHERWISE SPECIFIED		SIGNATURES		MO-DA-YR	
DIMENSIONS ARE IN MM		DRAWN		TITLE	
ALL SURFACES 6.3S		CHECKED		KJF 케이제이에프(주) TOTAL CLAMPING SYSTEMS	
TOLERANCES		APPROVED		HINGE CLAMP	
ANGLE		WORK ORDER NO		REF DWG NO.	
X ±				CLM05-FN	
.X ± 0.15				DWG NO	
.XX ±				QHGC-3048G-RH_-	
FINISH				SCALE	
HEAT TREAT				TOOL <input type="checkbox"/> PART <input type="checkbox"/> SHEET <input type="checkbox"/> OF	
				A3	