

FILE NAME:

REVISIONS

ZONE	LTR	DESCRIPTION	DATE	APPROVED
△				

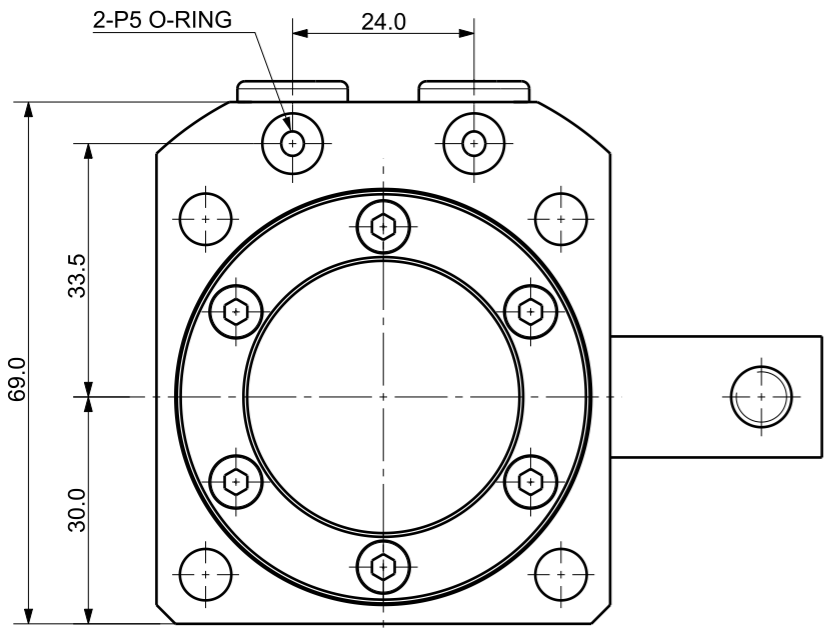

VIEW "B"

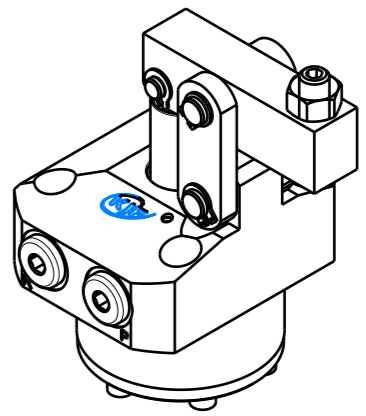
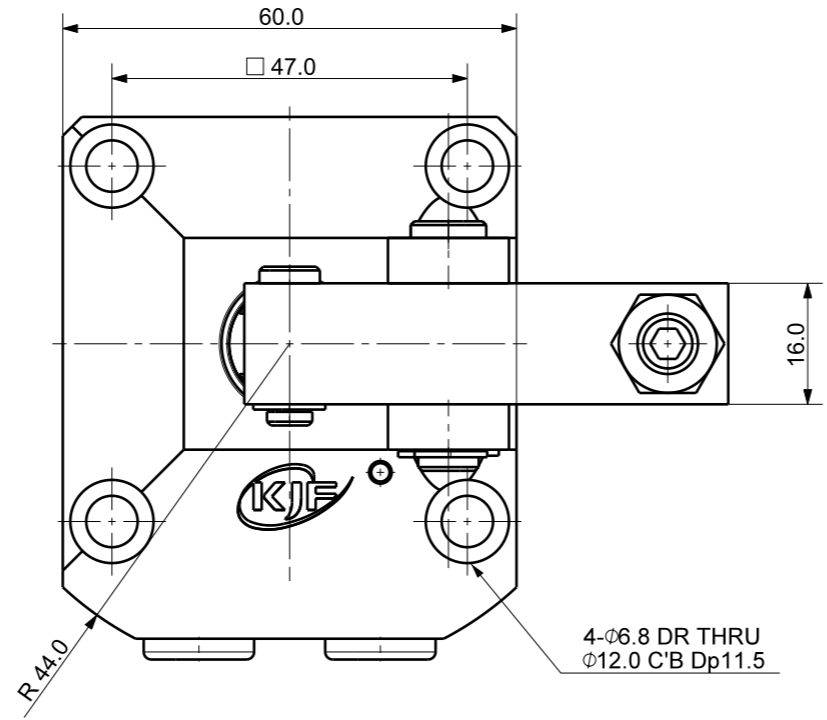

Isometric view (1:2)

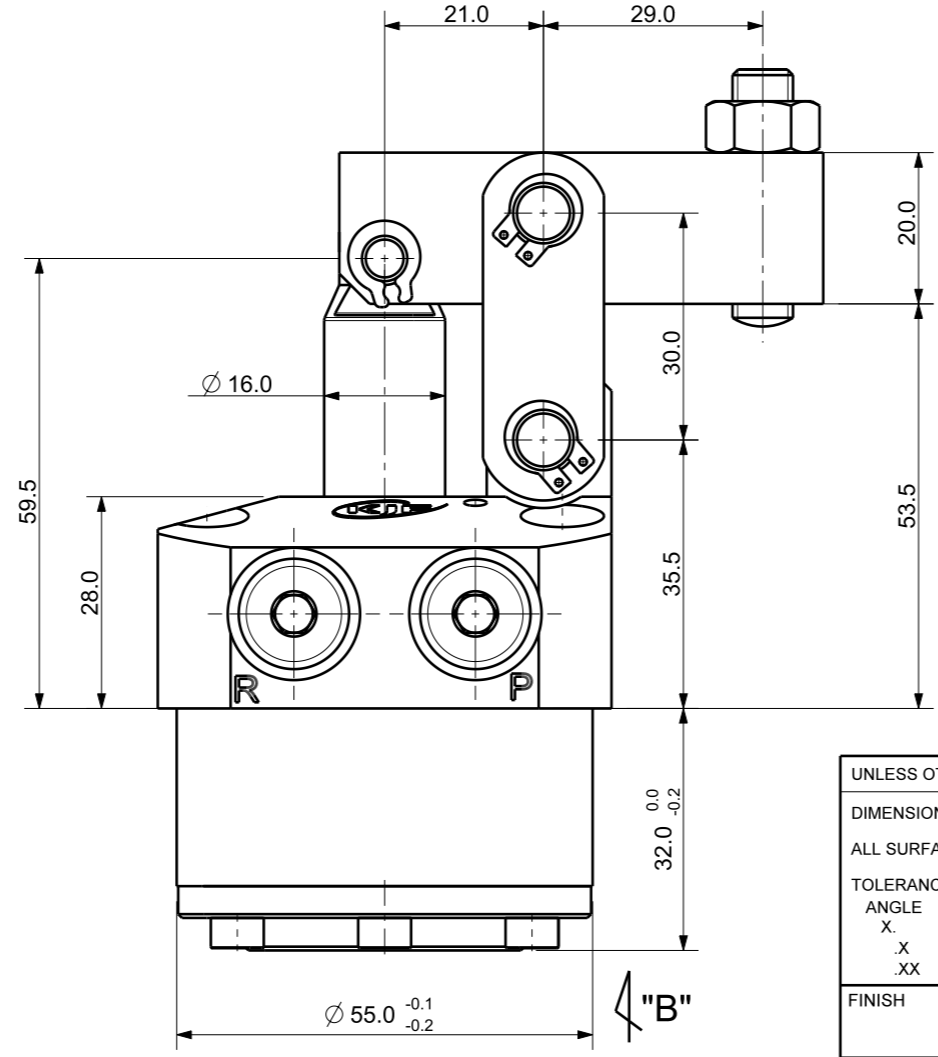
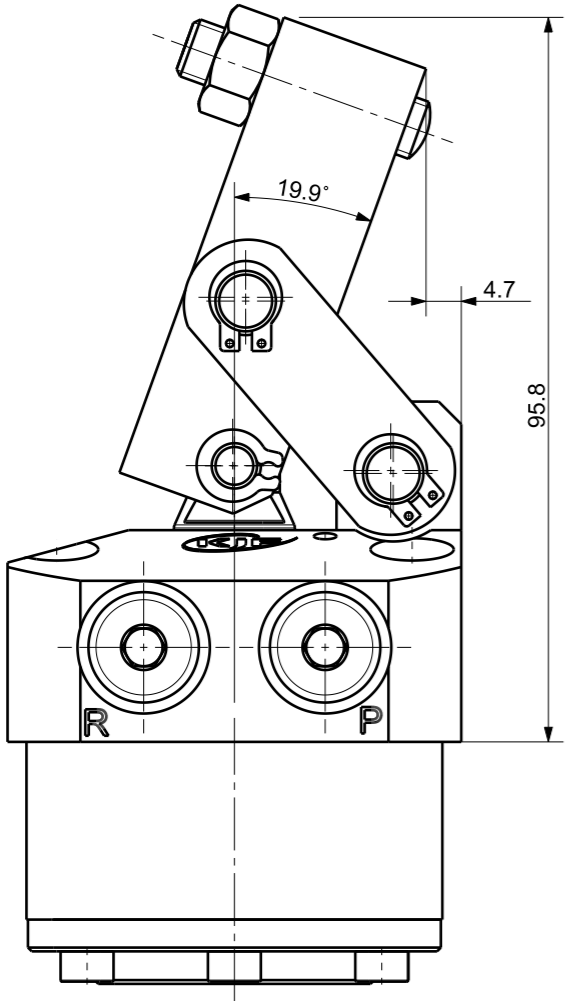

"B"

UNLESS OTHERWISE SPECIFIED  
 DIMENSIONS ARE IN MM  
 ALL SURFACES 6.3S  
 TOLERANCES  
 ANGLE ±  
 .X ± 0.15  
 .XX ±  
 FINISH  
 HEAT TREAT

DET. NO	NAME	QTY	MAT'L	FINAL SIZES & PART No	REMARK
SIGNATURES		MO-DA-YR		 케이제이에프(주) TOTAL CLAMPING SYSTEMS TITLE <h3>HINGE CLAMP</h3>	
DRAWN					
CHECKED					
APPROVED				REF DWG NO. ---	
WORK ORDER NO		DWG NO		QHG-3555G-RH_- A3	
		SCALE		TOOL <input type="checkbox"/> PART <input type="checkbox"/> SHEET OF	