

FILE NAME:

REVISIONS

ZONE	LTR	DESCRIPTION	DATE	APPROVED
------	-----	-------------	------	----------

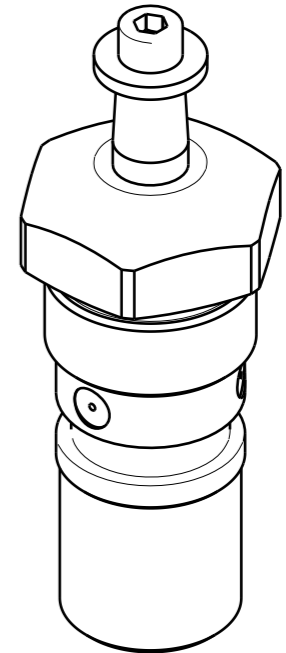
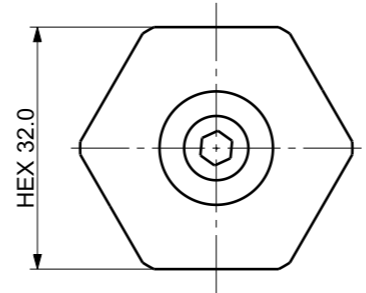
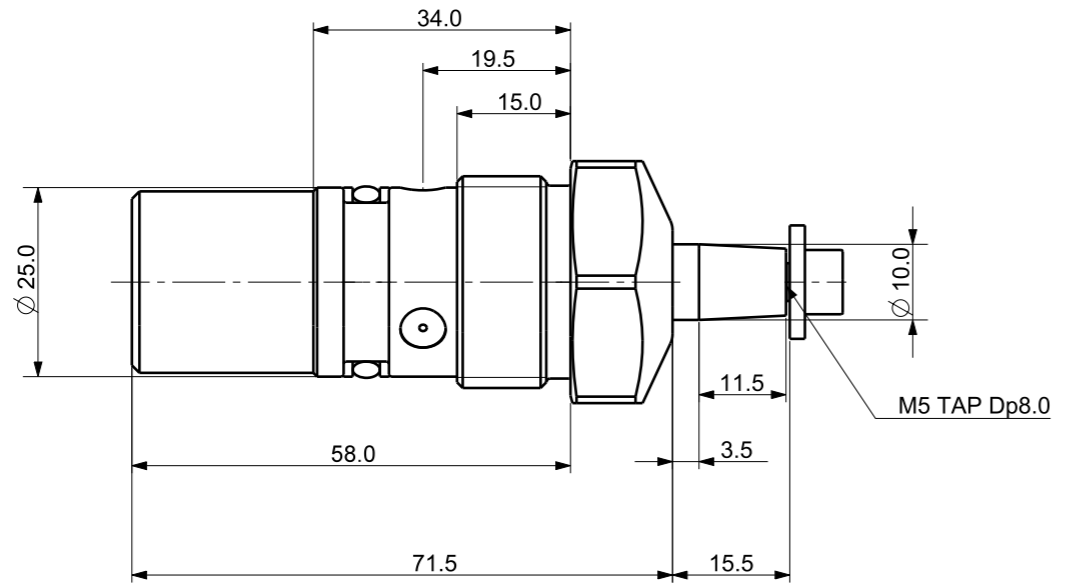

Isometric view (1:1)

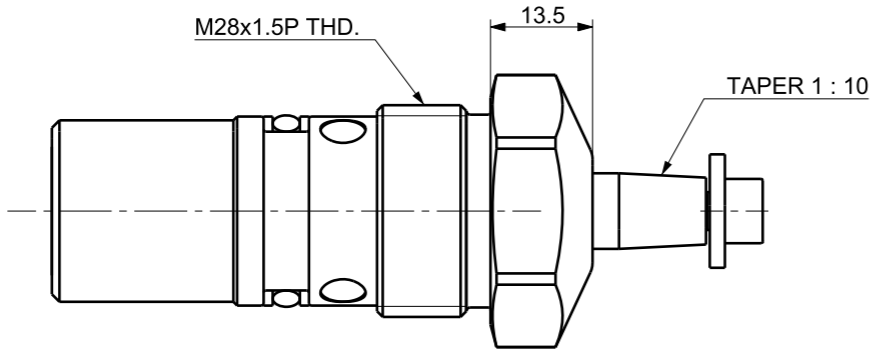

DET. NO	NAME	QTY	MAT'L	FINAL SIZES & PART No	REMARK
UNLESS OTHERWISE SPECIFIED		SIGNATURES		MO-DA-YR	
DIMENSIONS ARE IN MM		DRAWN		TITLE	
ALL SURFACES 6.3S		CHECKED		APPROVED	
TOLERANCES		WORK ORDER NO		REF DWG NO.	
ANGLE		HEAT TREAT		DWG NO	
X ±				1850-115	
.X ± 0.15				RSDx-1416C_F	
.XX ±				A3	
				SCALE / TOOL <input type="checkbox"/> PART <input type="checkbox"/> SHEET OF	



SWING CLAMP