

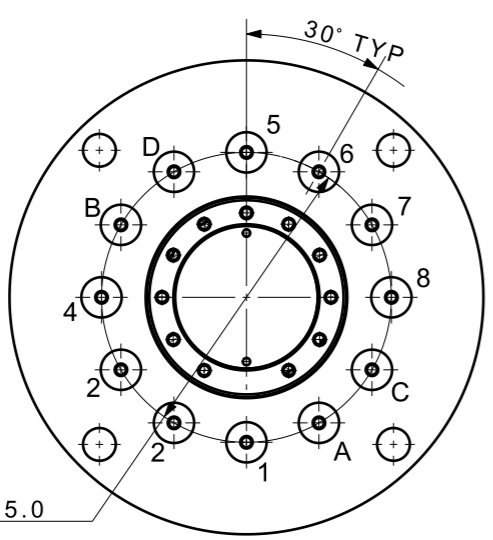

FILE NAME:

REVISIONS

ZONE	LTR	DESCRIPTION	DATE	APPROVED
------	-----	-------------	------	----------

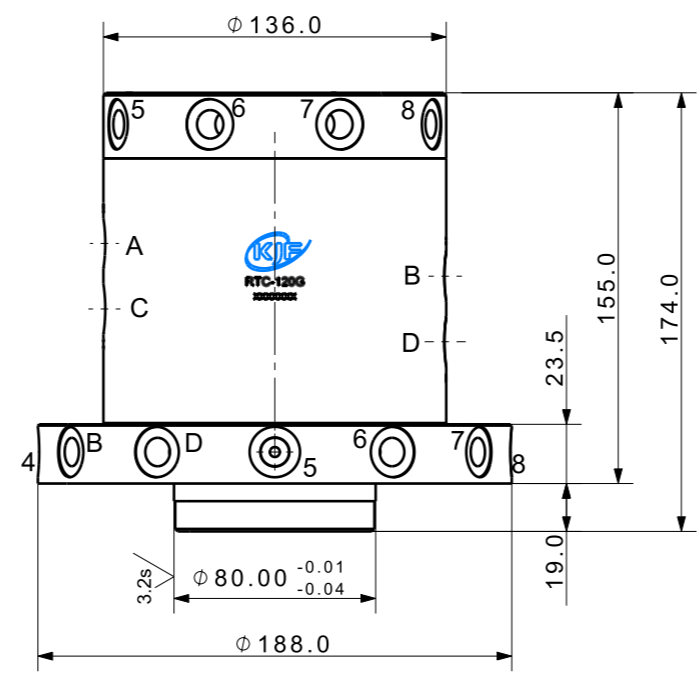
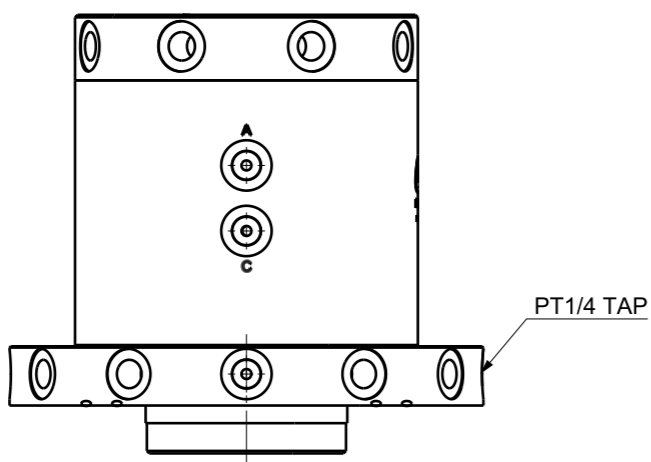
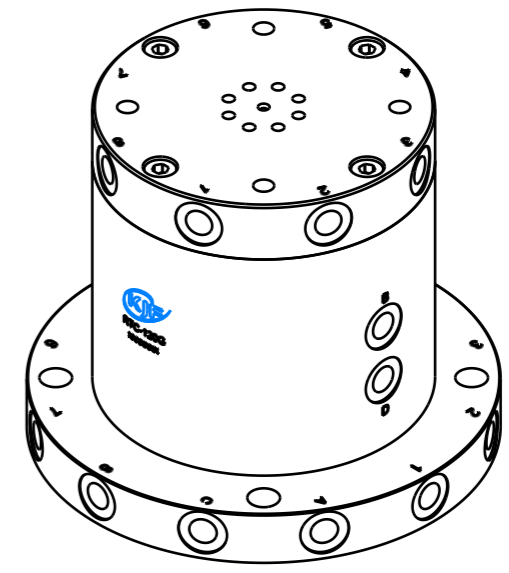
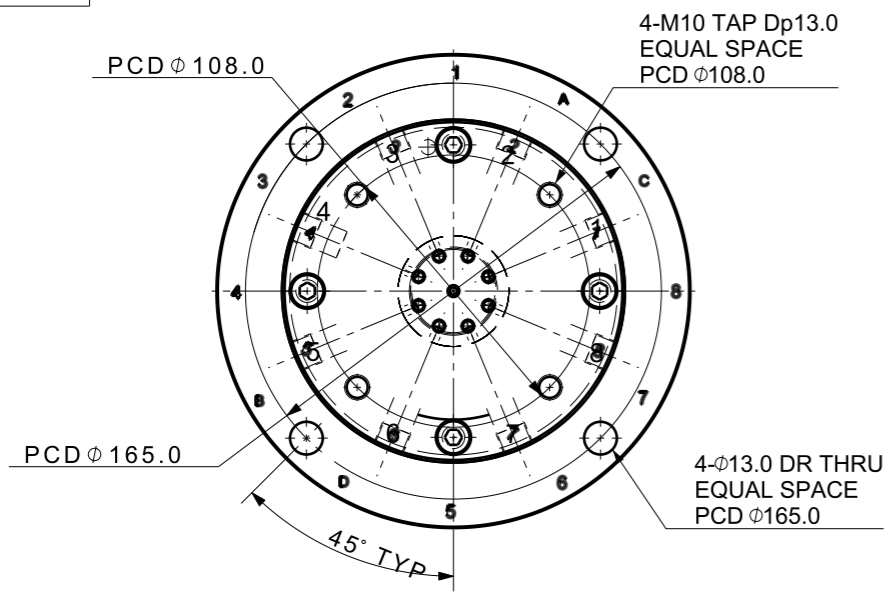

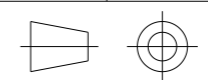
DET. NO	NAME	QTY	MAT'L	FINAL SIZES & PART No	REMARK
UNLESS OTHERWISE SPECIFIED		SIGNATURES		MO-DA-YR	 케이제이에프(주) TOTAL CLAMPING SYSTEMS
DIMENSIONS ARE IN MM		DRAWN	OYS	00-00-00	
ALL SURFACES 6.3S		CHECKED			
TOLERANCES		APPROVED		TITLE	
ANGLE				ROTARY JOINT	
X ±					
.X ± 0.15					
.XX ±					
FINISH		WORK ORDER NO		REF DWG NO.	DWG NO
BLOCK OXIDE				---	RTC-120_-
HEAT TREAT				SCALE	TOOL <input type="checkbox"/> PART <input type="checkbox"/> SHEET <input type="checkbox"/> OF
HRC18~22					A3