

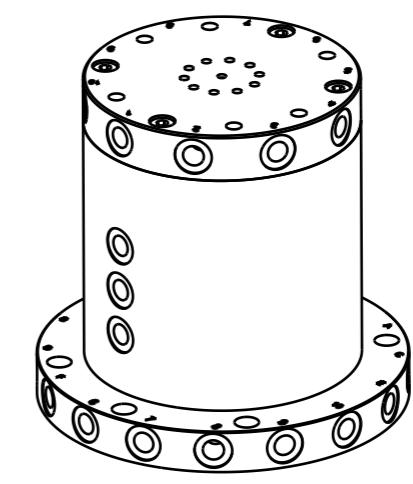

FILE NAME:

REVISIONS				
ZONE	LTR	DESCRIPTION	DATE	APPROVED

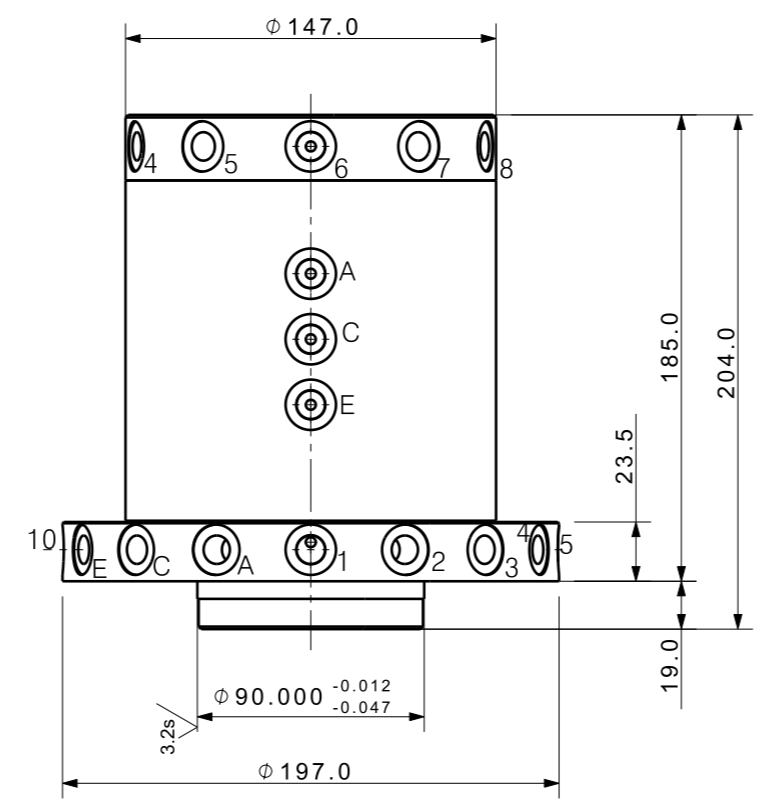
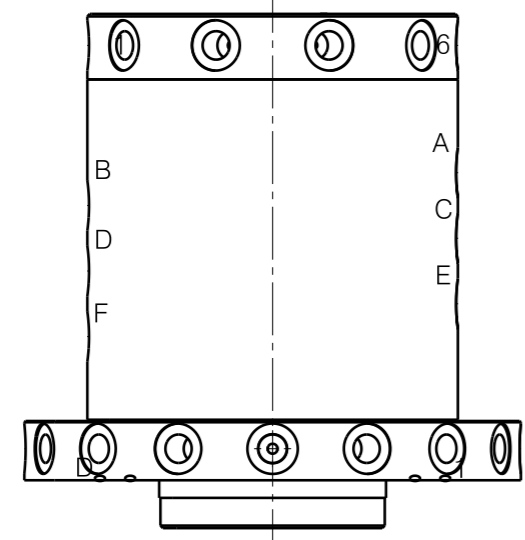
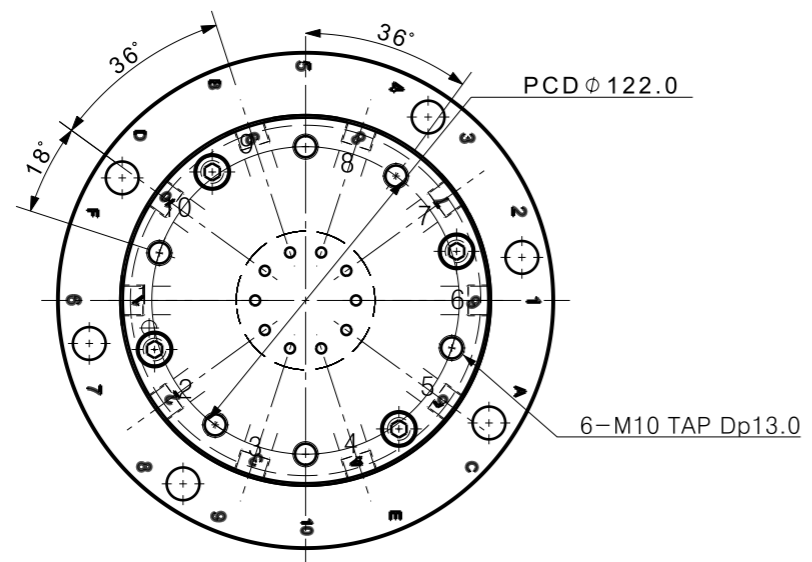
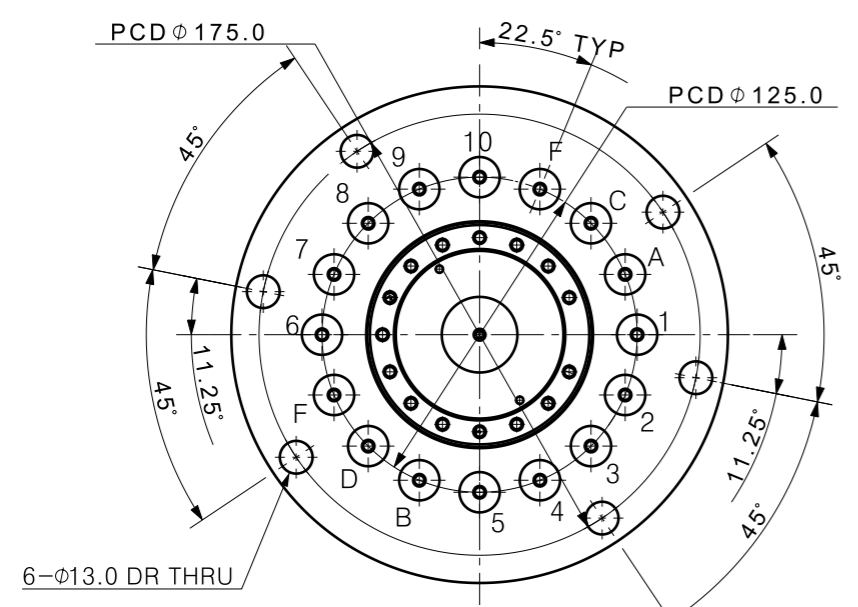

Isometric view (1:4)



DET. NO	NAME	QTY	MAT'L	FINAL SIZES & PART No	REMARK	
UNLESS OTHERWISE SPECIFIED	SIGNATURES	MO-DA-YR	 케이제이에프(주) TOTAL CLAMPING SYSTEMS			
DIMENSIONS ARE IN MM	DRAWN OYS	00-00-00				TITLE
ALL SURFACES 6.3S	CHECKED					ROTARY JOINT
TOLERANCES	APPROVED					
ANGLE			WORK ORDER NO	REF DWG NO.	DWG NO	
X. \pm				JRY1600-002	RTC-160_-	A3
.X ± 0.15				SCALE	TOOL <input type="checkbox"/> PART <input type="checkbox"/> SHEET	OF
.XX \pm						
FINISH	BLOCK OXIDE					
HEAT TREAT	HRC18~22					