

FILE NAME:

REVISIONS

ZONE	LTR	DESCRIPTION	DATE	APPROVED
------	-----	-------------	------	----------

4- ϕ 5.5 HOLE THRU
 ϕ 9.0 C'B Dp6.0
 M6 TAP Dp10.0
 (BOTH END)

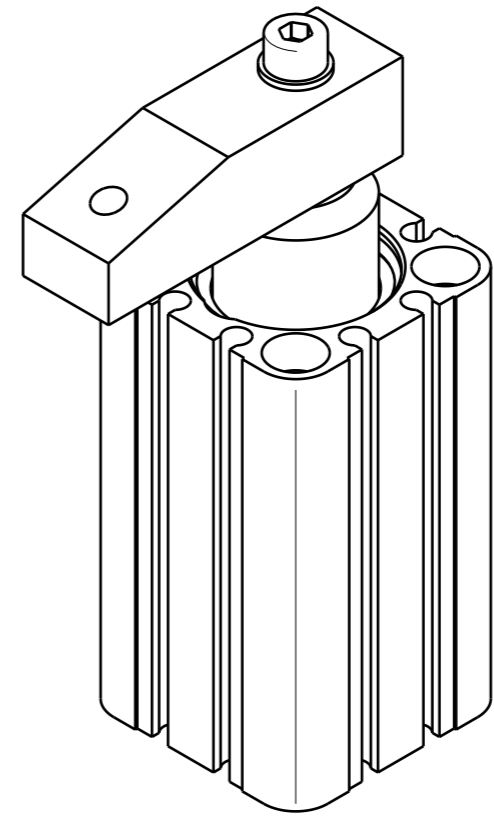
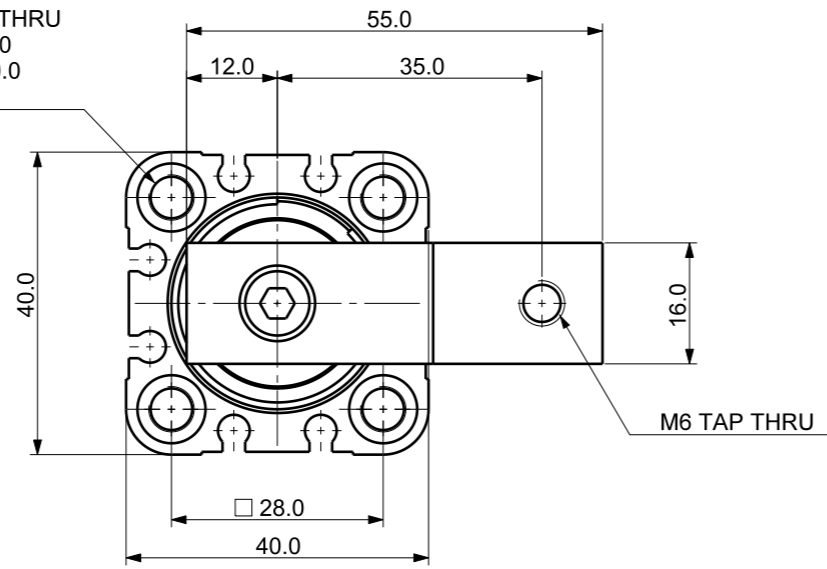

Isometric view (1:1)

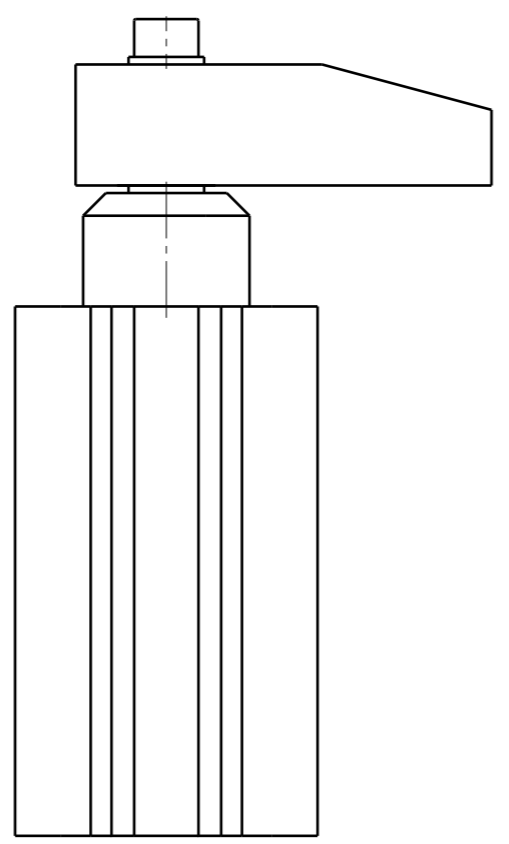
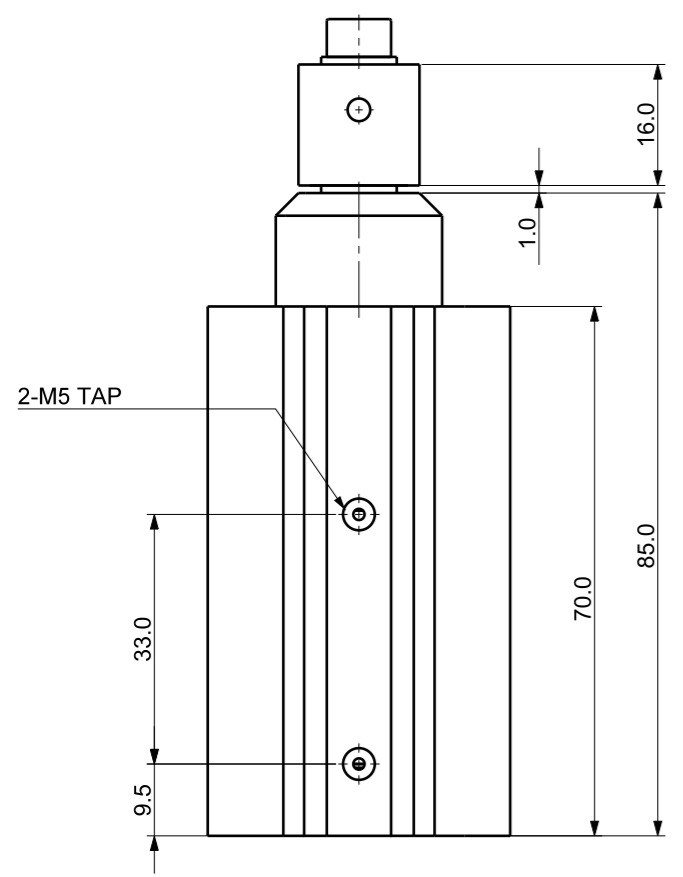

NOTE
 1. STROKE : 18.0mm
 straight : 10.0mm
 swing : 8.0mm

DET. NO	NAME	QTY	MAT'L	FINAL SIZES	REMARK
---------	------	-----	-------	-------------	--------

UNLESS OTHERWISE SPECIFIED	SIGNATURES	MO-DA-YR
DIMENSIONS ARE IN MM	DRAWN ---	---
ALL SURFACES 6.3S	CHECKED	
TOLERANCES	APPROVED	
ANGLE		
X. ±		
.X ± 0.15		
.XX ±		
FINISH ---	WORK ORDER NO	
HEAT TREAT ---		

KJF 케이제이에프(주)
 TOTAL CLAMPING SYSTEMS

TITLE
AIR SWING CLAMP

REF DWG NO. DWG NO. **SDx-2518AE_A** **A3**

SCALE / TOOL PART SHEET OF