

FILE NAME:

REVISIONS				
ZONE	LTR	DESCRIPTION	DATE	APPROVED

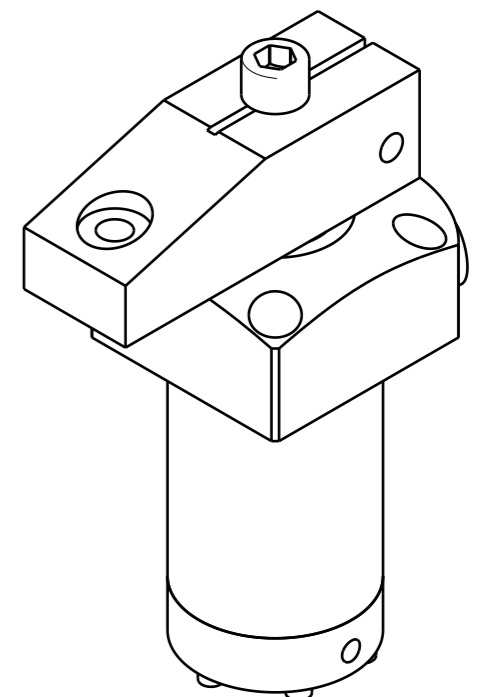
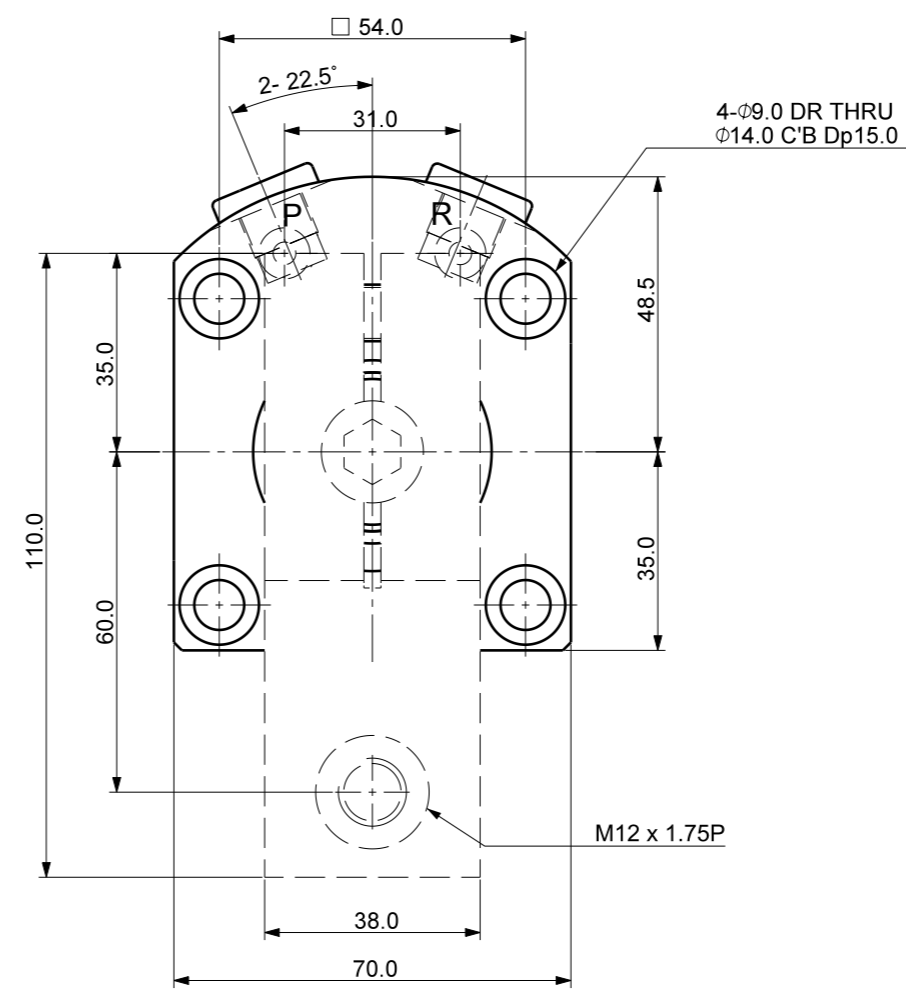
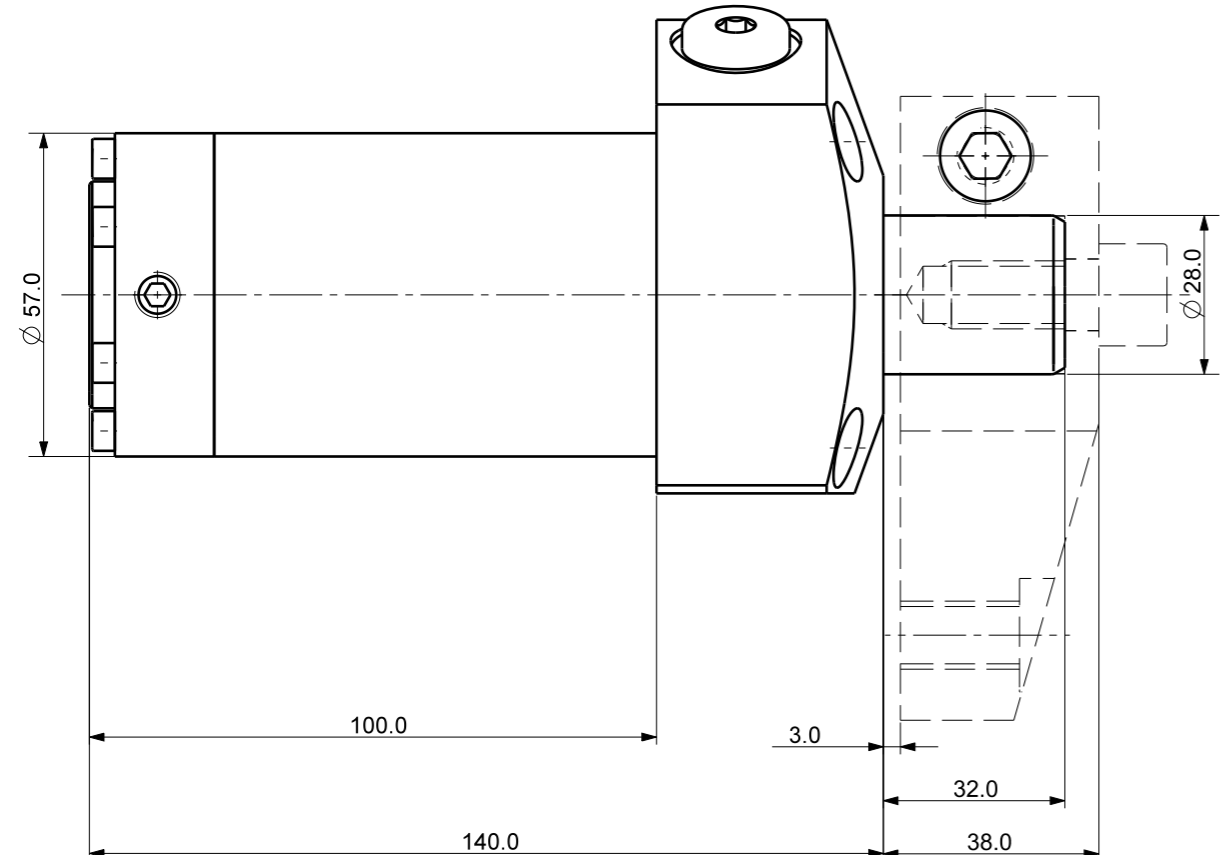
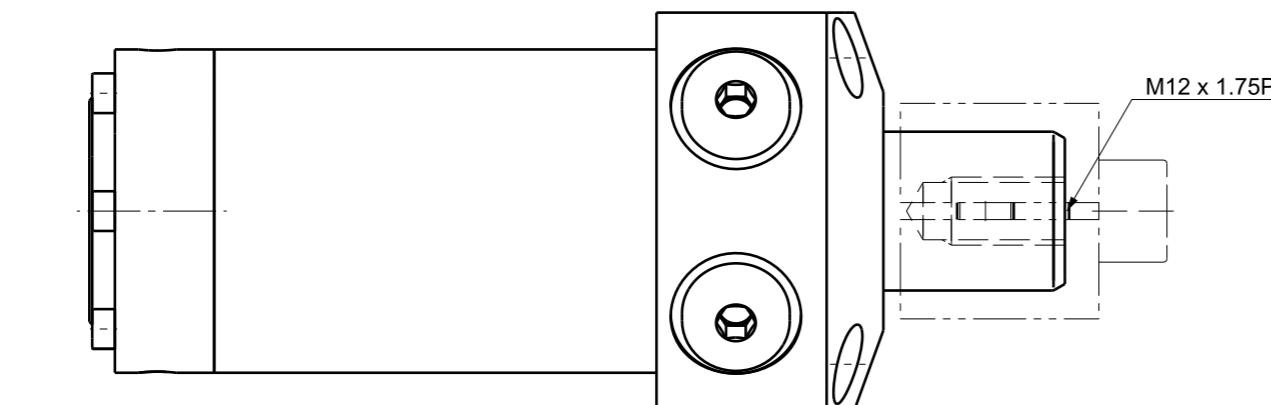

Isometric view (1:2)

DET. NO	NAME	QTY	MAT'L	FINAL SIZES & PART No	REMARK

UNLESS OTHERWISE SPECIFIED	SIGNATURES	MO-DA-YR
DIMENSIONS ARE IN MM	DRAWN	
ALL SURFACES 6.3S	CHECKED	
TOLERANCES	APPROVED	
ANGLE ±		
X ±		
.X ± 0.15		
.XX ±		
FINISH	WORK ORDER NO	
HEAT TREAT		

 케이제이에프(주) TOTAL CLAMPING SYSTEMS	
TITLE	
HYD. SWING CLAMP	
REF DWG NO.	DWG NO
---	SDx-4045G
SCALE	TOOL <input type="checkbox"/> PART <input type="checkbox"/> SHEET OF
	A3