

FILE NAME:

REVISIONS

ZONE	LTR	DESCRIPTION	DATE	APPROVED
------	-----	-------------	------	----------

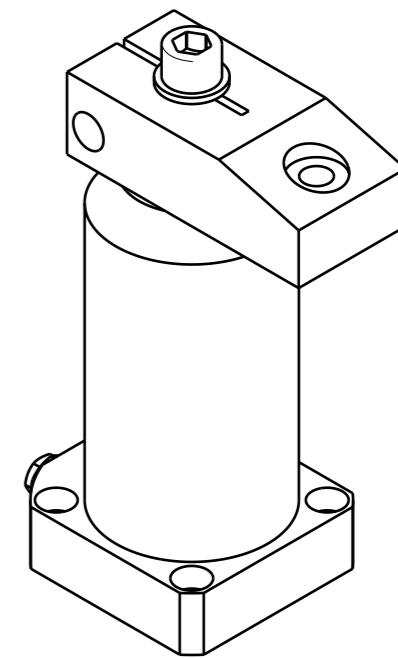
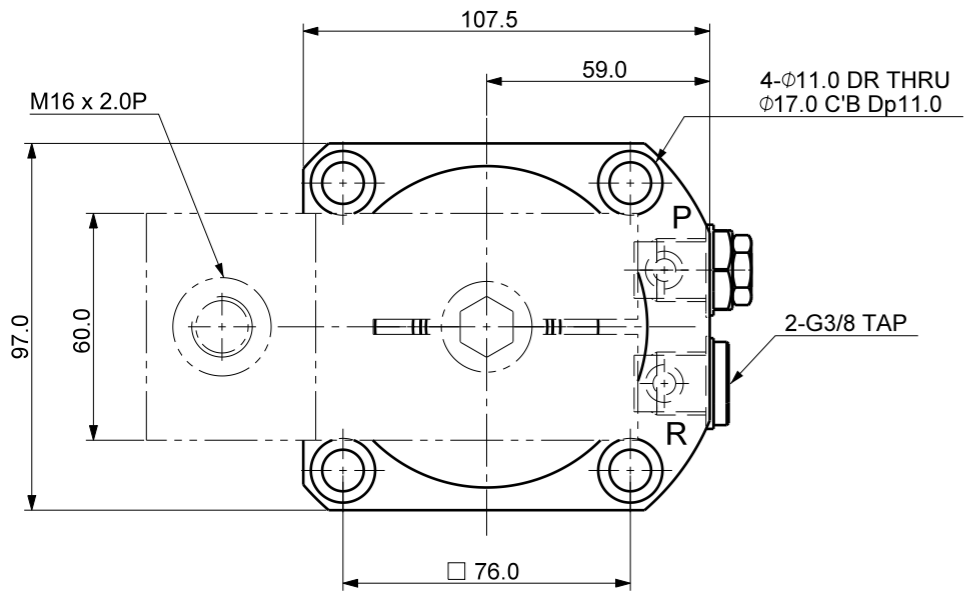

Isometric view (1:3)

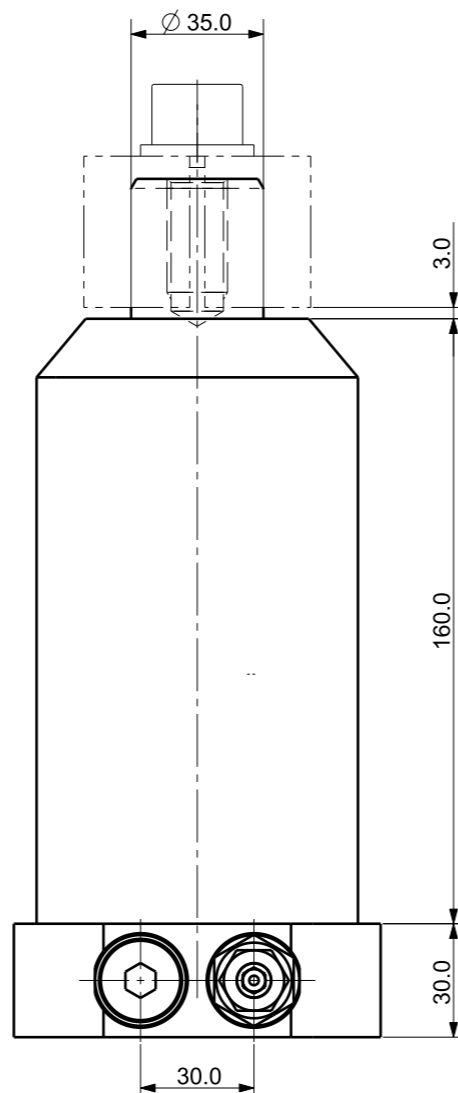
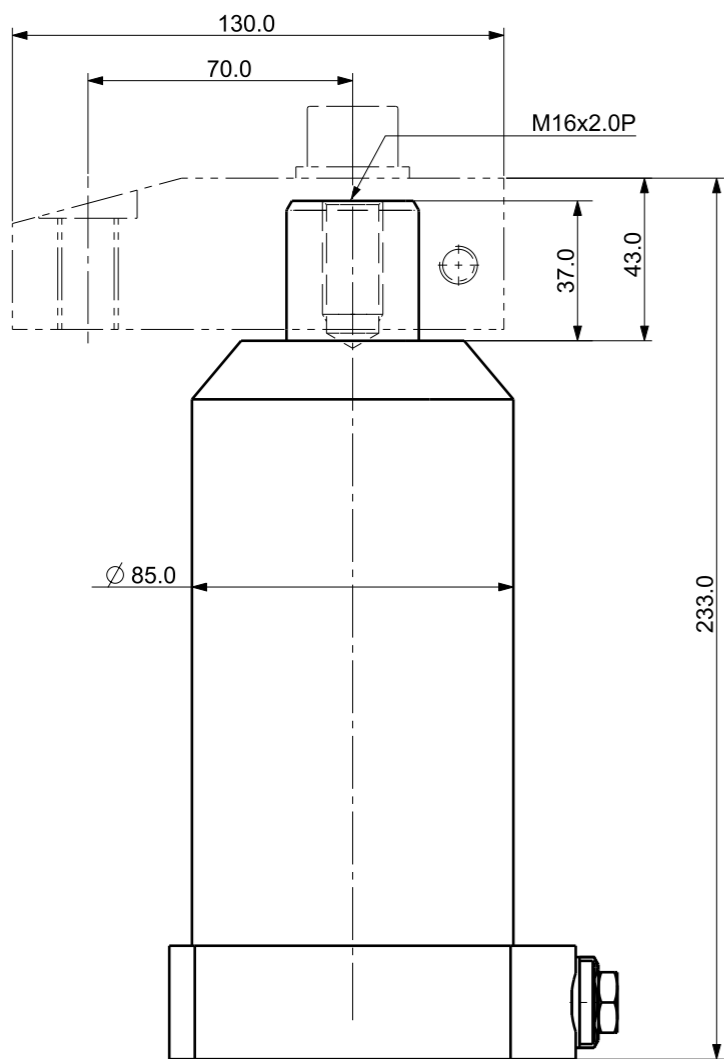

DET. NO	NAME	QTY	MAT'L	FINAL SIZES & PART No	REMARK
UNLESS OTHERWISE SPECIFIED		SIGNATURES		MO-DA-YR	
DIMENSIONS ARE IN MM		DRAWN		TITLE	
ALL SURFACES 6.3S		CHECKED		KJF 케이제이에프(주) TOTAL CLAMPING SYSTEMS	
TOLERANCES		APPROVED		HYD. SWING CLAMP	
ANGLE		WORK ORDER NO		REF DWG NO.	
X. $\pm$				DWG NO	
.X $\pm$ 0.15				SDx-5555FGV	
.XX $\pm$				A3	
FINISH		SCALE 1/2		TOOL <input type="checkbox"/> PART <input type="checkbox"/> SHEET OF	
HEAT TREAT					