

FILE NAME:

REVISIONS

ZONE	LTR	DESCRIPTION	DATE	APPROVED
------	-----	-------------	------	----------

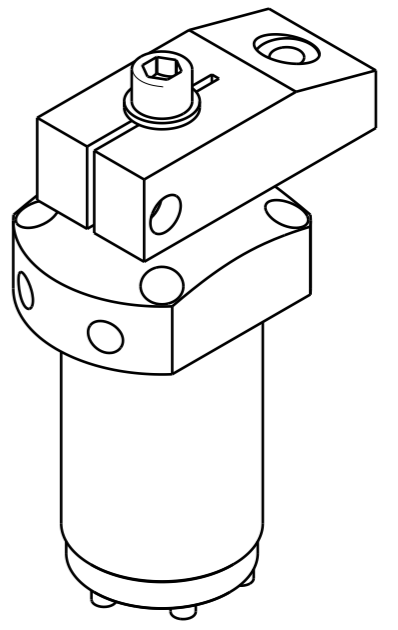
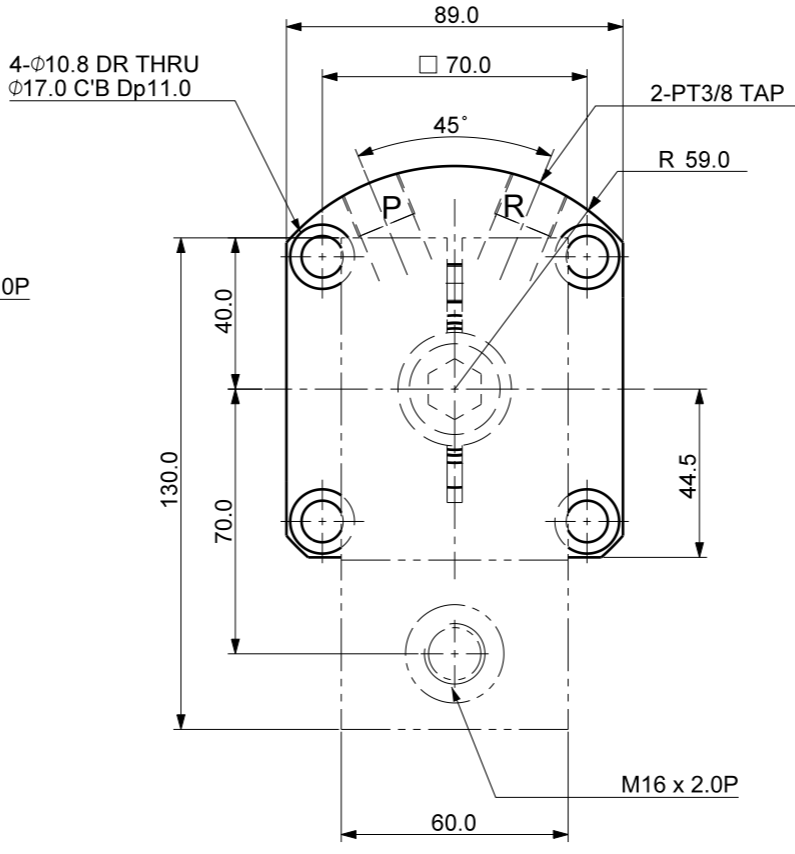
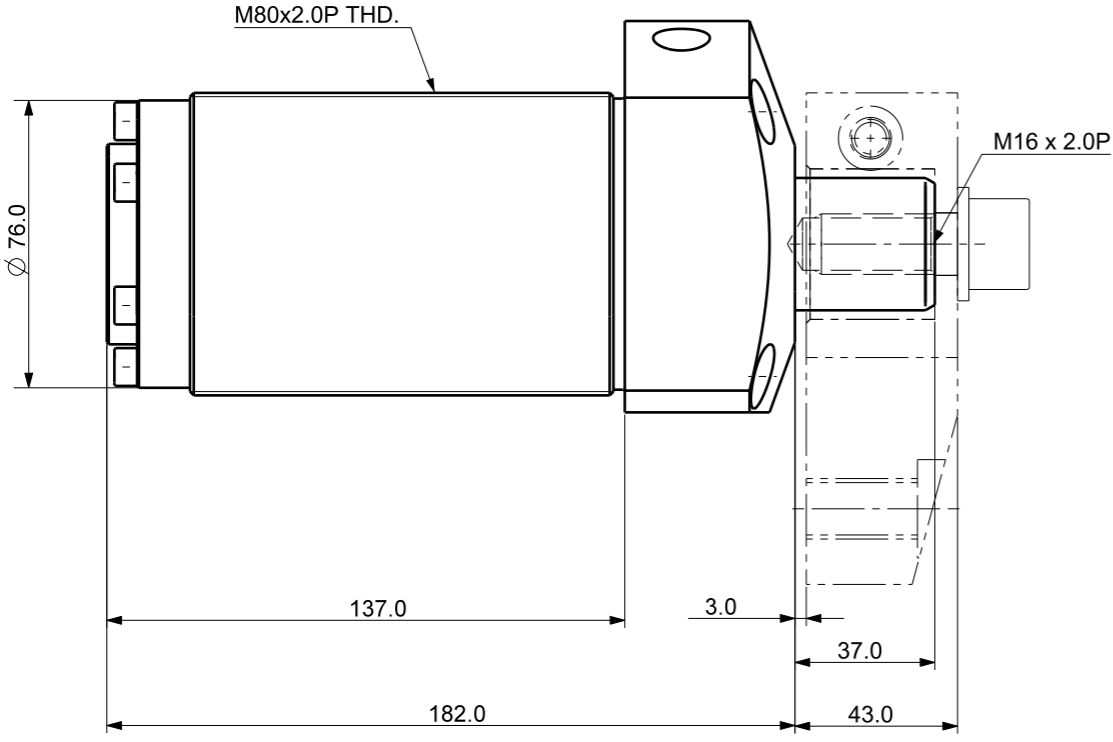
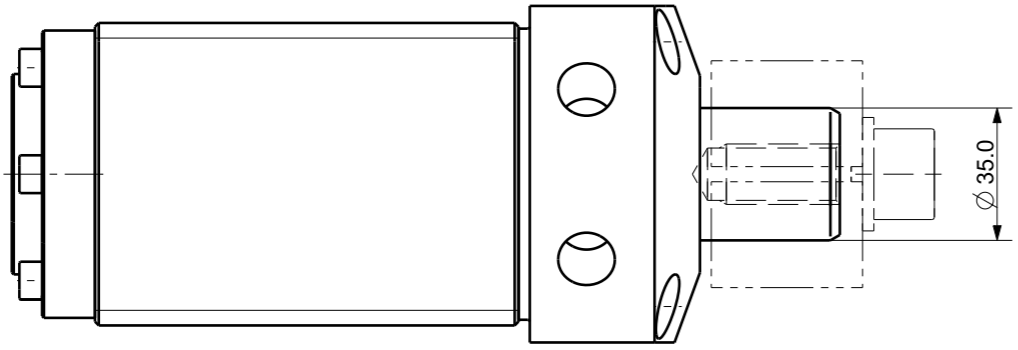

Isometric view (1:3)

DET. NO	NAME	QTY	MAT'L	FINAL SIZES & PART No	REMARK
UNLESS OTHERWISE SPECIFIED		SIGNATURES		MO-DA-YR	
DIMENSIONS ARE IN MM		DRAWN		TITLE	
ALL SURFACES 6.3S		CHECKED		KJF 케이제이에프(주) TOTAL CLAMPING SYSTEMS	
TOLERANCES		APPROVED		SWING CLAMP	
ANGLE ±		X ±		REF DWG NO. ---	
.X ± 0.15		.XX ±		DWG NO. SDx-5555	
FINISH		WORK ORDER NO		SCALE 1/2	
HEAT TREAT				TOOL <input type="checkbox"/> PART <input type="checkbox"/> SHEET <input type="checkbox"/> OF	

A3